

R557F-1



Radiant
Systems

Preassembled manifold with fixed point regulation, for heating systems

Datasheet/Instruction
0900EN 04/2026
047U57748

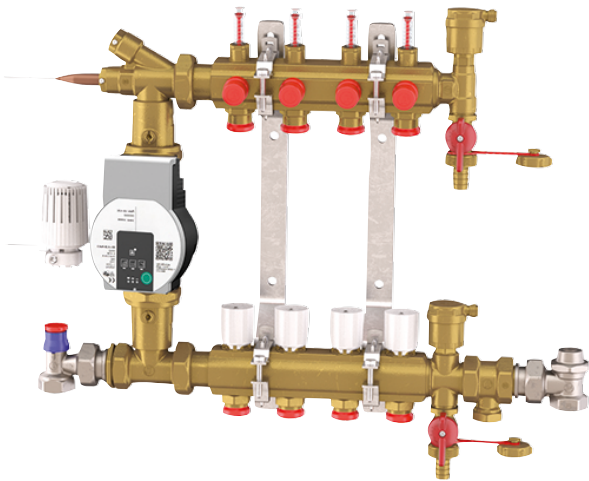

R557F-1 manifold is used in those applications where in the same housing unit, are installed heat sources supplied at high temperature water and radiant panel circuits to be supplied with low temperature water.

The manifold permits to distribute the heating fluid in circuits of the radiant heating system at a prefixed working temperature, set through R462L thermostatic head, by drawing from a primary circuit at higher temperature, needed for the operation of other users (for example radiators).

➤ Versions and product codes

PRODUCT CODE	CONNECTIONS PRIMARY x OUTLETS	N° OUTLETS	CABINET L x A x P [mm]
R557FY124		4	
R557FY125		5	850 x 605 x 150 (R557Y051)
R557FY126		6	
R557FY127		7	
R557FY128	G 3/4" x 3/4"E	8	
R557FY129		9	
R557FY130		10	1000 x 605 x 150 (R557Y052)
R557FY131		11	
R557FY132		12	

Included components

- R401TG valve with thermostatic option (iron connection)
- R14TG lockshield (iron connection)
- Pump Wilo Para 25/7 (centre distance 130 mm), ErP compliant
- R462L thermostatic head

Completion codes

- K373 safety thermostat
- R557I metallic cabinet
- R473, R473M, R478, R478M thermo-electric actuators

Technical data

Performance

- Temperature range: 5+110 °C
- Max. working pressure: 10 bar
- Fluids of use: water with glycol for HVAC systems
- Max. glycol percentage: 30%
- Outlets center distance: 50 mm
- Supply water temperature: 75+80 °C
- Working temperature difference: ΔT 6+7 °C
- Working temperature for low temperature water usage points: 40+45 °C (position 2,5 / 3 of thermostatic head R462L)
- Temperature range of thermostatic head R462L: 20+70 °C
- Self-modulating pump 25/7, center distance 130 mm

Materials

- Manifold and main components: EN 12165 CW617N brass
- Return manifold handwheels: plastic
- Metallic cabinet: galvanized sheet metal
- Seals: EPDM

Losses of pressure

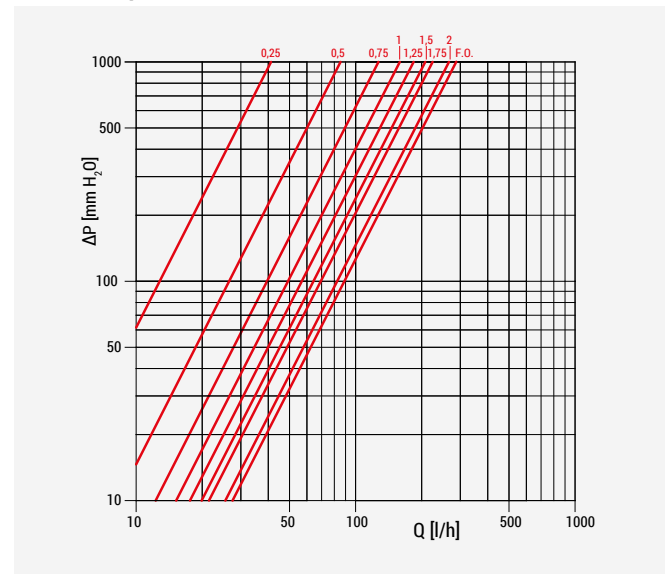

Components

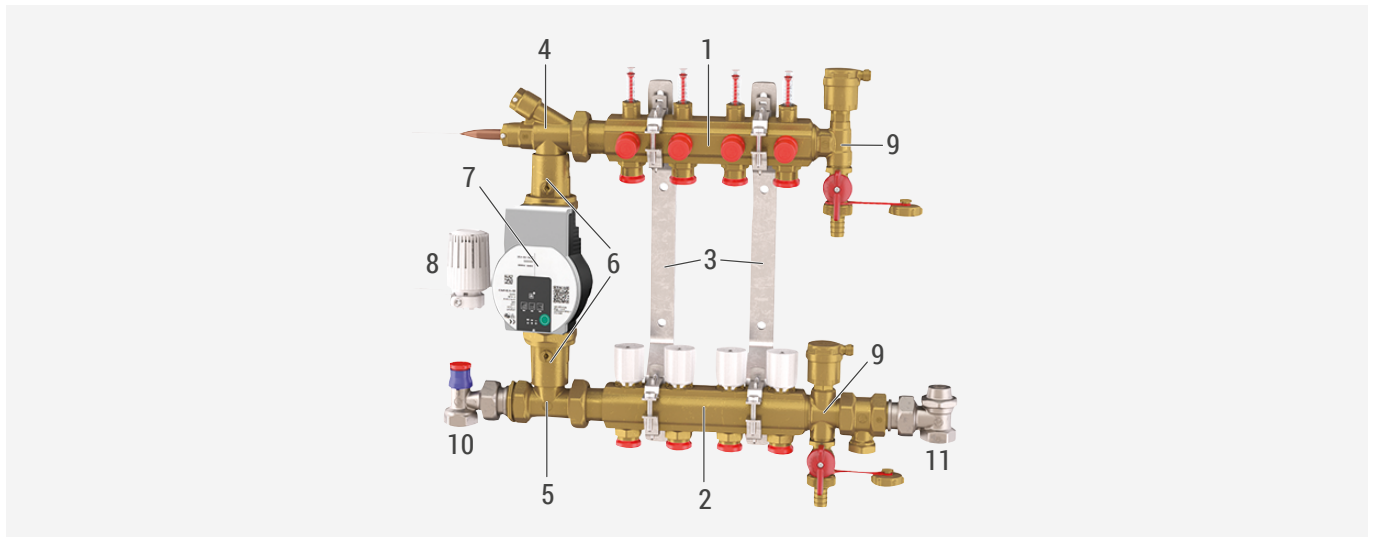

- | | |
|---|--|
| 1 | R553M supply manifold with frontal balancing lockshield and flow meters (scale 0,5+5 l/min) |
| 2 | R553V return manifold with shut-off valves and manual handwheels, predisposed for electrothermal control |
| 3 | R588L metallic adjustable brackets |
| 4 | R557B supply fitting with housing for probes |
| 5 | R557D mixing fitting |
| 6 | R252 shut-off ball valves for pump |

- | | |
|----|---|
| 7 | Pump Wilo Para 25/7 |
| 8 | R462L thermostatic head |
| 9 | Unit with automatic air vent valve and drain cock |
| 10 | Valve with thermostatic option |
| 11 | Lockshield |

Installation

WARNING. Installation must be carried out by authorized and qualified personnel.

Thermostatic head regulation

The supply temperature of the radiant system is presetted by positioning R462L thermostatic head according to the correspondences of the below table.

To avoid possible tampering of the position, by using the proper metallic ring nut, it is possible to lock the head preset.

R462L THERMOSTATIC HEAD POSITION	F.C.	1	2	3	4	5	F.O.
TEMPERATURE [°C]	20	25	34	45	56	67	70

Circuit balancing

The supply manifold is equipped with micrometric lockshields with mechanical memory, for the circuit balancing.

To set the mechanical memory use the R558N key screwdriver to completely open the ring nut, then use the Allen wrench to set the lockshield to the desired values (ref. to losses of pressure diagram).

When circuits are balanced, screw again all ring nuts.

This operation will allow closing the circuits in successive times and reopen them without losing the initial calibration position.

Thermo-electric actuators installation

If the R557F-1 manifold supplies circuits that heat the same room, the most efficient way to regulate the room temperature is with a thermostat, that stops directly the pump by interposing a simple timer that limits frequent starting and switching off. If the R557F-1 manifold supplies circuits that heat different rooms, you can obtain the greatest comfort and energy saving by installing in each room thermostats connected to thermo-electric actuators of the R473, R473M, R478, R478M series. Actuators can be easily installed on the return manifold, by removing manual handwheels, install the ring nut supplied with the actuator's package and then fit the actuator on the ring nut turning it by about 15° until a click is heard.

Example of electrical connection

The diagram represents a typical case of mixed system in which high temperature heat sources (for example radiators or toweldryers) are combined with R557F-1 manifolds for radiant floor heating systems.

The electrical system shall be made so as to ensure primary circuit pump start when the manifold pump works.

The scheme shall be revised depending on the assembled actuator and on the system complexity, by adopting the appropriate compatible electrical components.

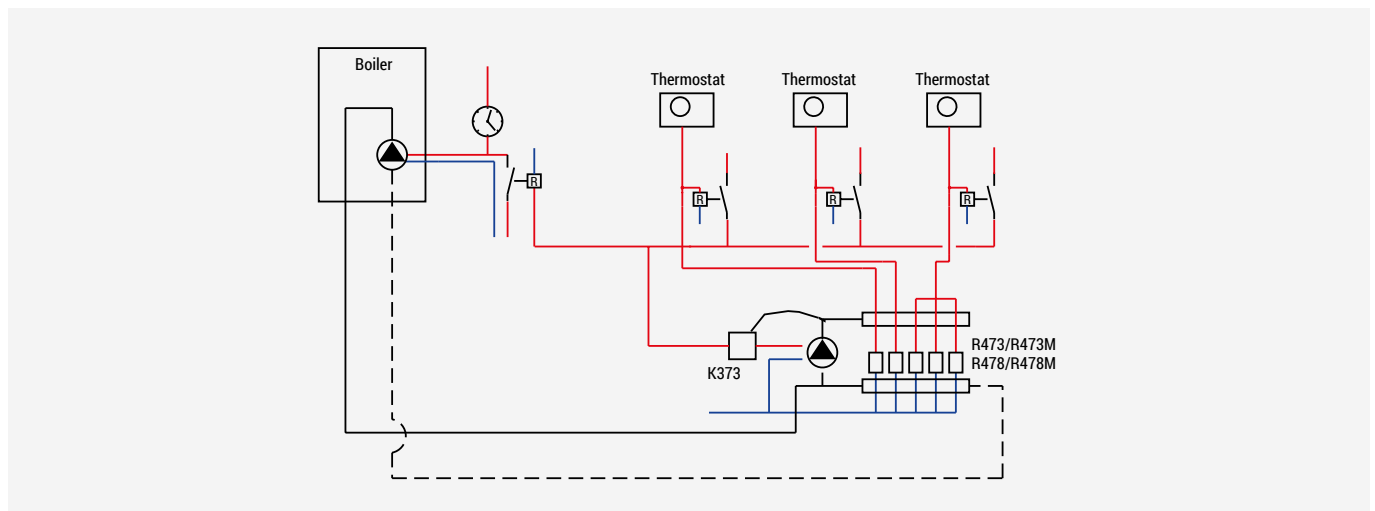

➤ Pump features

Constant differential pressure Δp -c (I, II, III) [RECOMMENDED]

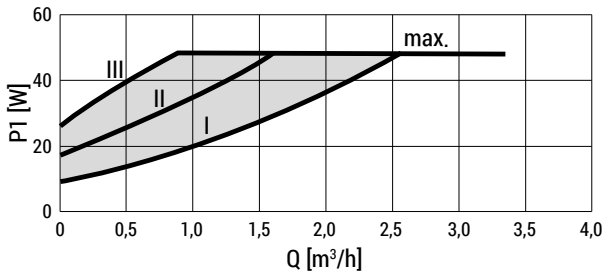
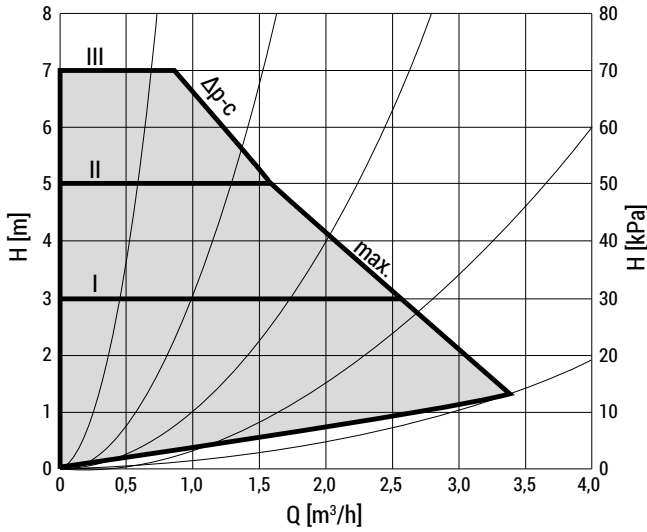

Variable differential pressure Δp -v (I, II, III)

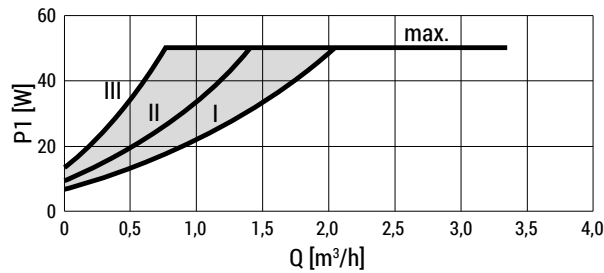
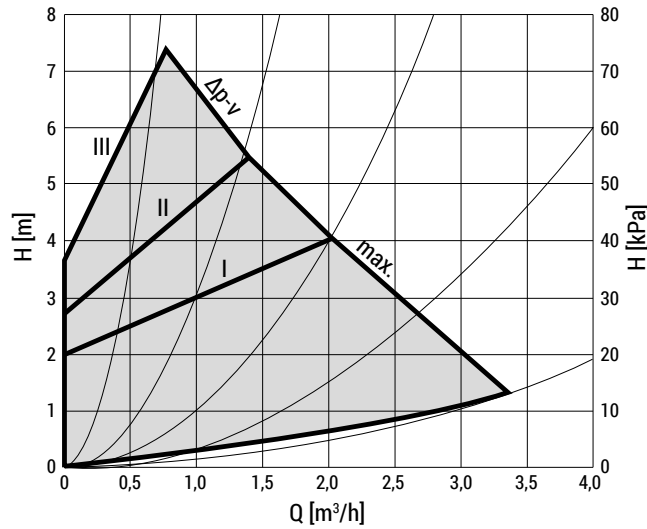

Setting the control mode

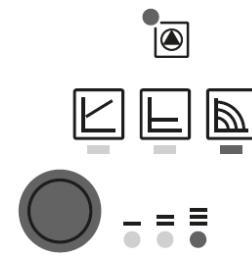

The LED selection of control modes and corresponding pump curves takes place in clockwise succession.

- Press the operating button briefly (approx. 1 second).

- ☑➔ LEDs display the set control mode and pump curve.

Air venting



- Fill and vent the system correctly.

If the pump does not vent automatically:

- Activate the pump venting function via the operating button: press and hold for 3 seconds, then release.

- ☑➔ The pump venting function is initiated and lasts 10 minutes.

- ☑➔ The top and bottom LED rows flash in turn at 1 second intervals.

- To cancel, press and hold the operating button for 3 seconds.

After venting, the LED display shows the previously set values of the pump.

Recommended for two-pipe heating systems with radiators to reduce the flow noise at thermostatic valves. The pump reduces the supply head to half in the case of decreasing volume flow in the pipe network.

Electrical energy saving by adjusting the supply head to the volume flow requirement and lower flow rates.

There are three pre-defined pump curves (I, II, III) to choose from.

Constant speed (I, II, III) [FACTORY SETTING]

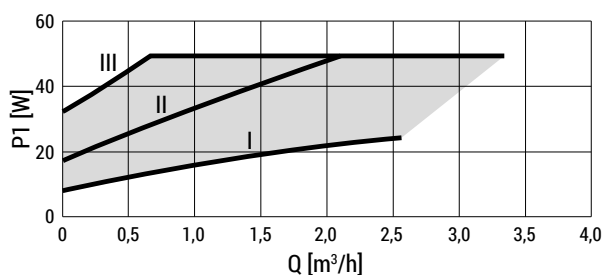
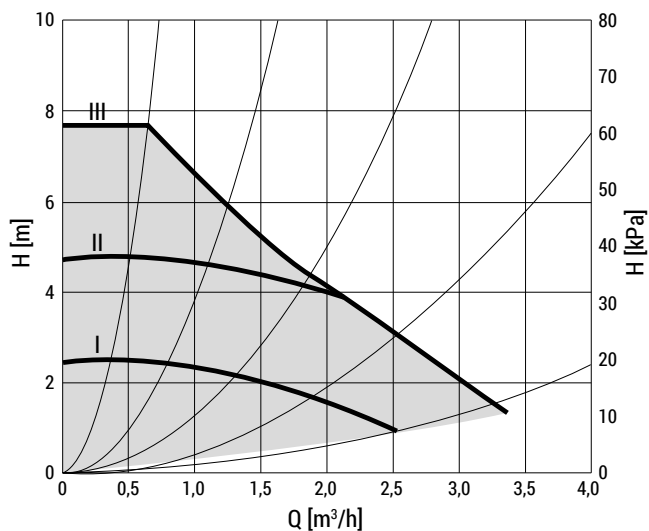

Recommended for systems with fixed system resistance requiring a constant volume flow. The pump runs in three prescribed fixed speed stages (I, II, III).

Fault signals

- The fault signal LED indicates a fault.
- The pump switches off (depending on the fault) and attempts a cyclical restart.

LED	Faults	Causes	Remedy
 Lights up red 	Blocking	Rotor blocked	Activate manual restart or acontact customer service
	Contacting/winding	Winding defective	
Flashing red 	Under/overvoltage	Power supply too low/high on mains side	Check mains voltage and operating conditions, and request customer service
	Excessive module temperature	Module interior too warm	
	Short-circuit	Motor current too high	
Flashes red/ green 	Generator operation	Water is flowing through the pump hydraulics, but there is no mains voltage at the pump	Check the mains voltage, water quantity/pressure and the ambient conditions
	Dry run	Air in the pump	
	Overload	Sluggish motor, pump is operated outside of its specifications (e.g. high module temperature). The speed is lower than during normal operation	

Dimensions

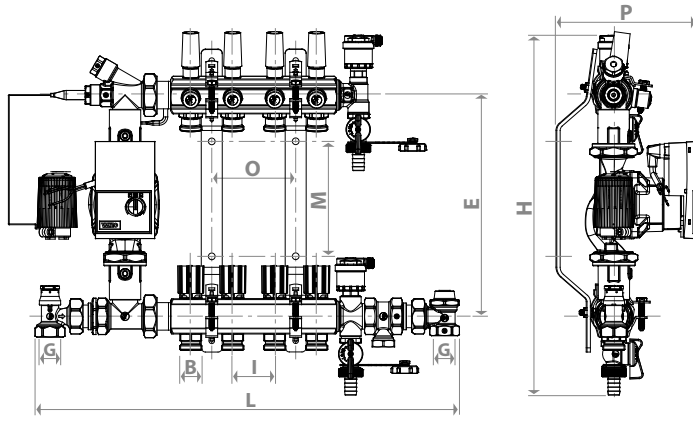

PRODUCT CODE	N° OUTLETS	G x B	I [mm]	H [mm]	E [mm]	M [mm]	O [mm]	L [mm]	P [mm]
R557FY124	4	G 3/4" F x 3/4" E	50	430÷470	264÷304	137	100	505	282/109*
R557FY125	5	G 3/4" F x 3/4" E	50	430÷470	264÷304	137	150	555	282/109*
R557FY126	6	G 3/4" F x 3/4" E	50	430÷470	264÷304	137	200	605	282/109*
R557FY127	7	G 3/4" F x 3/4" E	50	430÷470	264÷304	137	250	655	282/109*
R557FY128	8	G 3/4" F x 3/4" E	50	430÷470	264÷304	137	300	705	282/109*
R557FY129	9	G 3/4" F x 3/4" E	50	430÷470	264÷304	137	350	755	282/109*
R557FY130	10	G 3/4" F x 3/4" E	50	430÷470	264÷304	137	400	805	282/109*
R557FY131	11	G 3/4" F x 3/4" E	50	430÷470	264÷304	137	450	855	282/109*
R557FY132	12	G 3/4" F x 3/4" E	50	430÷470	264÷304	137	500	905	282/109*

* with pump installed laterally

⚠ Safety Warning. Installation, commissioning and periodical maintenance of the product must be carried out by qualified operators in compliance with national regulations and/or local standards. A qualified installer must take all required measures, including use of Individual Protection Devices, for his and others' safety. An improper installation may damage people, animals or objects towards which Giacomini S.p.A. may not be held liable.

♻ Package Disposal. Carton boxes: paper recycling. Plastic bags and bubble wrap: plastic recycling.

ℹ Additional information. For more information, go to giacomini.com or contact our technical assistance service. This document provides only general indications. Giacomini S.p.A. may change at any time, without notice and for technical or commercial reasons, the items included herewith. The information included in this technical sheet do not exempt the user from strictly complying with the rules and good practice standards in force.

♻ Product Disposal. Do not dispose of product as municipal waste at the end of its life cycle. Dispose of product at a special recycling platform managed by local authorities or at retailers providing this type of service.