

Automatic air vent valve, ideal for solar thermal systems



R99SY003



R99SY013

The R99S automatic air vent valve is ideal for use in solar thermal systems.

It bleeds off the air that forms in the solar circuit, especially during the system filling phase.

This avoids any negative effects that could jeopardise the efficiency and lifespan of the system.

It is made of special materials that allow operation at high temperatures with glycol water.

➤ Versions and product codes

SERIES	PRODUCT CODE	CONNECTIONS	FEATURE
R99S	R99SY003	G 1/2" M	With shut-off ball valve
	R99SY013	G 1/2" M	Without shut-off ball valve

➤ Technical data

- Temperature range: -20÷180 °C
- Max. working pressure: 10 bar
- Max. pressure of air vent operation: 5 bar
- Use fluids: water and glycol solutions (max. 50%)

Materials

- Body: UNI EN 12165 CW617N brass
- O-Ring: solar EPDM
- Stopper spring: stainless steel
- Internal float: high temperature resistance TPX

Performance

The table and the graph report the discharge air capacities, in standard conditions, at the change of the pressure of the system.



➤ Installation

The R99S automatic air vent valves are usually installed on the top of the solar panels and in the parts of the pipes where air pockets could form.

For installation on solar panels, use the 3-piece straight fitting (R20SC) and the T-fitting (R182).

It is advisable to place a pipe of about 40 cm between the T-fitting and the R99S valve.

After bleeding the air during the system filling and start-up phase, the valve must be intercepted by a ball valve (supplied) to ensure that the internal components are not exposed to high temperatures and continuous operating conditions.

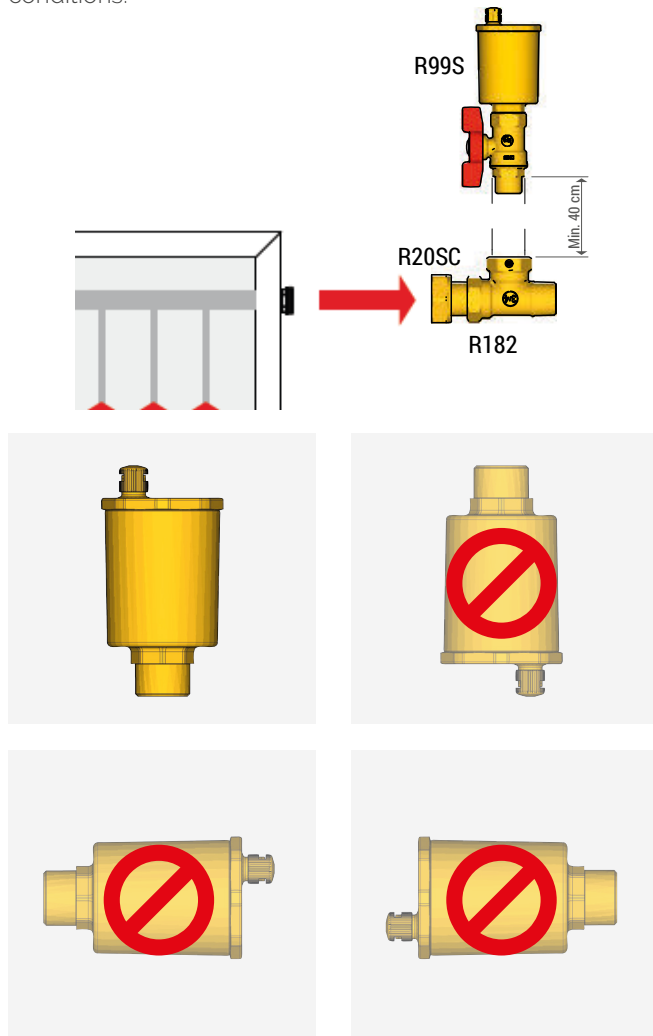

▲ WARNING. Close the cap of the air vent valve when rinsing out and filling the system, to prevent impurities from entering the mechanisms of the valve and damaging it.

➤ Operation

The operation of the automatic air vent valve is very simple and it is based on the principle of the floating of bodies immersed in a fluid.

When there is no air accumulation into the valve body, the float (A) is in raised position and through the mechanism, it keeps the stopper under closing.

The lowering of the floating level caused by the air accumulation into the valve body, involves the stopper opening and the consequent discharge that persists up to the reintroduction of the normal conditions.

At the system filling, as there is no water into the valve body, the float is completely down permitting the air to flow quickly.

The air discharge is prevented by screwing the lateral plug. In normal operation conditions, the plug shall be unscrewed.

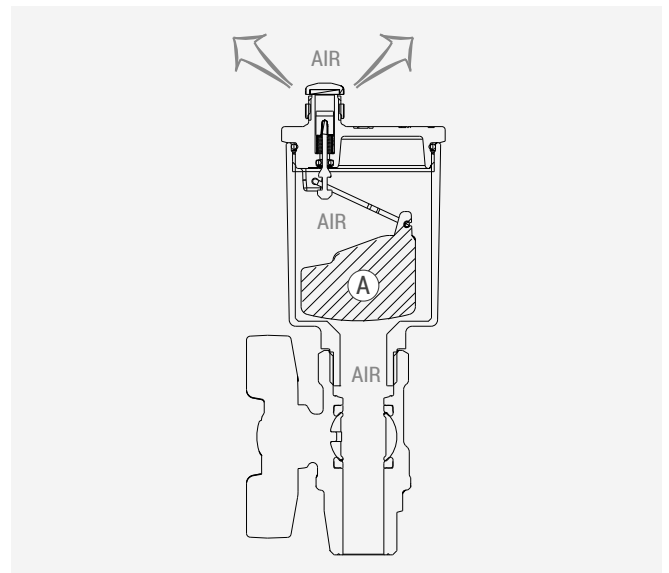
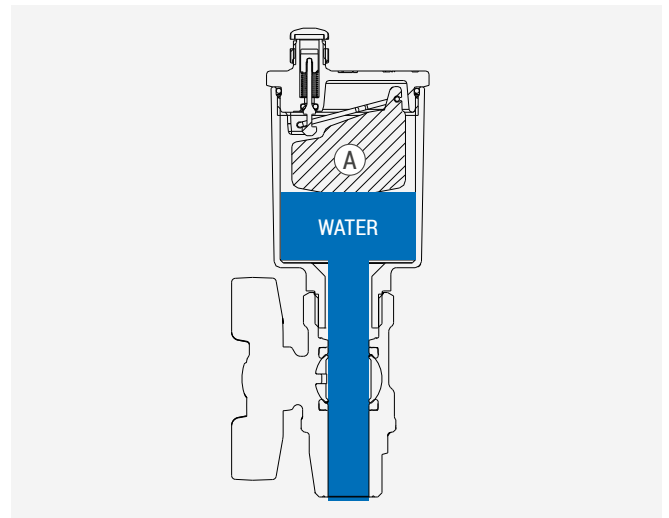

➤ Dimensions

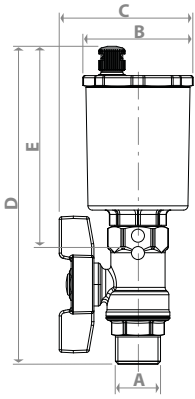

PRODUCT CODE	A	B [mm]	C [mm]	D [mm]	E [mm]
R99SY003	1/2" (G, ISO 228)	51	62	147	-
R99SY013	1/2" (G, ISO 228)	51	62	-	94

➤ Product specifications

R99SY003

Automatic air vent valve, ideal for solar thermal systems. Complete with shut-off ball valve. Body and cover in brass UNI EN 12165 CW617N. O-Ring in solar EPDM. Internal shutter spring in stainless steel. Float in TPX. Fluids: water and glycol solutions (max. 50 %). Temperature range -20÷180 °C. Max. working pressure 10 bar. Max. operating pressure of air vent 5 bar.

R99SY013

Automatic air vent valve, ideal for solar thermal systems. Body and cover in brass UNI EN 12165 CW617N. O-Ring in solar EPDM. Internal shutter spring in stainless steel. Float in TPX. Fluids: water and glycol solutions (max. 50 %). Temperature range -20÷180 °C. Max. working pressure 10 bar. Max. operating pressure of air vent 5 bar.

⚠ Safety Warning. Installation, commissioning and periodical maintenance of the product must be carried out by qualified operators in compliance with national regulations and/or local standards. A qualified installer must take all required measures, including use of Individual Protection Devices, for his and others' safety. An improper installation may damage people, animals or objects towards which Giacomini S.p.A. may not be held liable.

♻ Package Disposal. Carton boxes: paper recycling. Plastic bags and bubble wrap: plastic recycling.

ℹ Additional information. For more information, go to giacomini.com or contact our technical assistance service. This document provides only general indications. Giacomini S.p.A. may change at any time, without notice and for technical or commercial reasons, the items included herewith. The information included in this technical sheet do not exempt the user from strictly complying with the rules and good practice standards in force.

♻ Product Disposal. Do not dispose of product as municipal waste at the end of its life cycle. Dispose of product at a special recycling platform managed by local authorities or at retailers providing this type of service.