

R911



Energy
Management

Ball valve for water for heating systems, full port

Datasheet
0621EN  11/2023



DADO ball valve, with female-female threaded connections.
Full port.



Versions and product codes

PRODUCT CODE	CONNECTIONS	FINISHING	HANDLE TYPE	HANDLE COLOR	NOTES
R911X022	G 3/8"F x G 3/8"F	Nickel plated brass	T-handle	Red	DADO ball
R911X023	G 1/2"F x G 1/2"F	Nickel plated brass	T-handle	Red	DADO ball
R911X024	G 3/4"F x G 3/4"F	Nickel plated brass	T-handle	Red	DADO ball
R911X025	G 1"F x G 1"F	Nickel plated brass	T-handle	Red	DADO ball
R911X026	G 1-1/4"F x G 1-1/4"F	Nickel plated brass	T-handle	Red	DADO ball

Technical data

Main features and materials

- Suitable for water for heating/cooling systems, not dangerous gas and liquid hydrocarbons*
- Full port
- Valve made of UNI EN 12165 CW617N nickel plated brass
- Stem with double O-Ring
- Nut with anti-corrosion coating, with guarantee seal and hologram
- Aluminium T-handle, red painted
- DADO ball

* Please consult Giacomini technical support, to check the compatibility of the product with the specific hydrocarbon.

Field of applications

- Min. working temperature: -20 °C with 50 % glycol solutions
- Max. working temperature with dry saturated steam: 185 °C with 1,05 MPa (10,5 bar)
- Max. working pressure at 20 °C with water and not dangerous gas: 4,2 MPa (42 bar) for 3/8", 1/2", 3/4"
3,5 MPa (35 bar) for 1", 1-1/4"
- Temperature range with liquid hydrocarbons*: -20=60 °C
- Max. working pressure at 20 °C with liquid hydrocarbons*: 1,2 MPa (12 bar)

Dimensions and Kv

PRODUCT CODE	DN	A [mm]	I [mm]	B [mm]	J [mm]	C [mm]	H [mm]	Kv
R911X022	10	49	25	48	13	63	wr.21	7
R911X023	15	56	28	56	16	63	wr.25	13,3
R911X024	20	62	31	64	21	73	wr.32	25,8
R911X025	25	76	38	72	25	73	wr.39	50,9
R911X026	32	86	43	82	30	73	wr.47	103

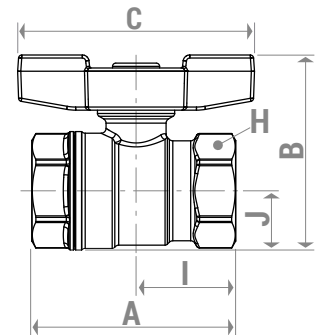

Product specifications

R911

DADO ball valve, with female-female threaded connections. Suitable for water for heating/cooling systems, not dangerous gas and liquid hydrocarbons. Valve made of UNI EN 12165 CW617N nickel plated brass. Full port. Aluminium T-handle, red painted. Stem with double O-Ring. Nut with anti-corrosion coating, with guarantee seal and hologram. Min. working temperature: -20 °C with 50 % glycol solutions. Max. working temperature with dry saturated steam: 185 °C with 1,05 MPa (10,5 bar). Max. working pressure at 20 °C with water and not dangerous gas: 4,2 MPa (42 bar) for 3/8", 1/2", 3/4"; 3,5 MPa (35 bar) for 1", 1-1/4". Temperature range with liquid hydrocarbons: -20=60 °C. Max. working pressure at 20 °C with liquid hydrocarbons: 1,2 MPa (12 bar).

⚠ Safety Warning. Installation, commissioning and periodical maintenance of the product must be carried out by qualified operators in compliance with national regulations and/or local standards. A qualified installer must take all required measures, including use of Individual Protection Devices, for his and others' safety. An improper installation may damage people, animals or objects towards which Giacomini S.p.A. may not be held liable.

♻ Package Disposal. Carton boxes: paper recycling. Plastic bags and bubble wrap: plastic recycling.

ℹ Additional information. For more information, go to giacomini.com or contact our technical assistance service. This document provides only general indications. Giacomini S.p.A. may change at any time, without notice and for technical or commercial reasons, the items included herewith. The information included in this technical sheet do not exempt the user from strictly complying with the rules and good practice standards in force.

♻ Product Disposal. Do not dispose of product as municipal waste at the end of its life cycle. Dispose of product at a special recycling platform managed by local authorities or at retailers providing this type of service.