

R626



Water
Management

Backflow preventer with controllable reduced pressure zone, BA type

Datasheet
0742EN  07/2023



The protection of the water supply plays a major role in modern systems.

To protect these water supplies, equipment must be installed on domestic systems to prevent backflow of potentially polluted water. These devices are called backflow preventers.

The backflow preventer, R626 series, is used to avoid health hazards caused by the backflow of polluted and/or contaminated water into the public drinking water distribution network after abnormal pressure variations.

The preventer must be installed between the public and "private" networks, so as to separate the two networks.

The backflow may be triggered either by back siphoning (due to a pressure drop in the distribution network, such as excessive diversion upstream) or by a pressure backflow (caused by a back pressure in the private network that exceeds that of the public network upstream).

Disconnection from the public distribution network is regulated by standard UNI EN 1717, which prescribes the use of backflow preventers upstream of the heating and air conditioning systems in utilities designed for hospital use, irrigation, livestock, food and fire-fighting equipment.

In particular, the R626 backflow preventer is designed for installation on water lines in environments where an undetected discharge may be the cause of serious damage to water (for example in a machinery room).

The choice of the preventer depends on several factors, including: pressure drop and required flow rate. The nominal diameter of the device must be equal to the nominal diameter of the pipe to which it is connected.

 **NOTE.** The backflow preventer, although marked PN10 in reference to standard EN 12729, is suitable for installation in fire-fighting networks with a maximum pressure of 12 bar.

➤ Versions and product codes

PRODUCT CODE	CONNECTIONS	VERSIONS	WEIGHT [kg]	
R626Y003	G 1/2"M	Threaded versions (threaded male connections with tail pieces)	1,45	
R626Y004	G 3/4"M		4	
R626Y005	G 1"M		4	
R626Y006	G 1-1/4"M		9	
R626Y007	G 1-1/2"M		9	
R626Y008	G 2"M		13	
<hr/>				
R626Y106	DN65		Flanged versions (flange in accordance with EN 1092)	30
R626Y108	DN80	40		
R626Y110	DN100	46		
R626Y115	DN150	73		

➤ Technical data

Performance

- Max. working temperature: 65 °C
- Max. working pressure: 10 bar
- Type BA (Classification according to UNI EN1717)
- Protection against fluids of categories: 1, 2, 3, 4 (UNI EN 1717)
- Complies with UNI EN 12729

Materials

- R626Y003: main body and covers in corrosion resistant brass (CR)
- R626Y004+008: main body and covers in bronze
- R626Y106+115: main body and covers in cast iron GJL250

Minimum flow rate values [m³/h] according to loss of pressure (according to EN 12729:2002)

CONNECT.	1/2"	3/4"	1"	1-1/4"	1-1/2"	2"	65	80	100	150
Δp 1 bar	1,9	3,4	5,3	8,7	13,6	21,2	35,8	54,3	84,8	190,9
Δp 1,5 bar	2,9	5,1	7,9	13	20,3	32,0	47,8	72,4	113,1	245,5

Loss of pressure for threaded versions

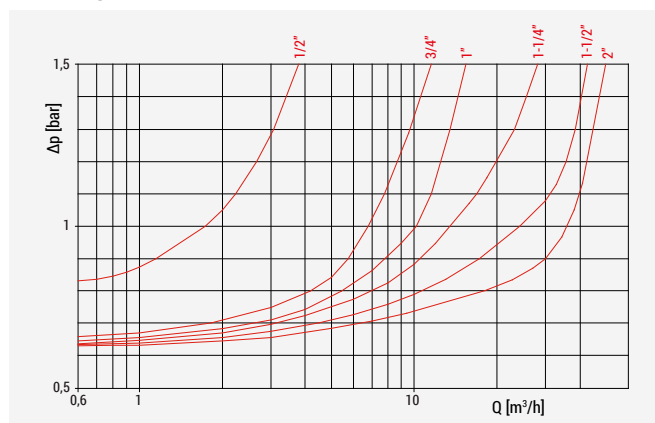

CONNECT.	1/2"	3/4"	1"	1-1/4"	1-1/2"	2"
Kv	1,76	6,7	9,7	13,5	25	38,6

Loss of pressure for flanged versions

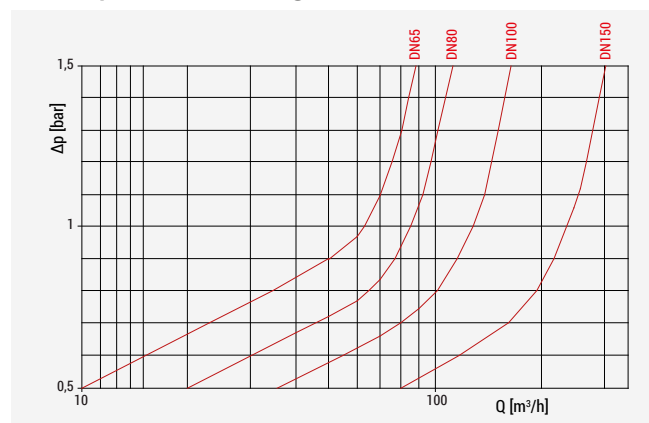

DN	65	80	100	150
Kv	64	85	129	235

➤ Operation

Normal operation: flow without anomalies

The pressure of the primary network overcomes the resistance of the two check valves (A and B), allowing supply to the different utilities.

Due to the loss of pressure of valve A, the pressure in the intermediate zone is at least 140 mbar lower than the pressure upstream.

This pressure difference acts on the diaphragm, blocking the return force of the spring, which would tend to open discharge valve C.

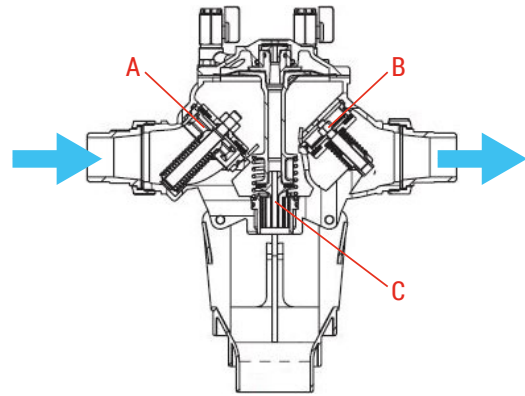

Stop of flow: static pressure

The check valves (A and B) close; the outlet remains closed.

Flow with anomalies: overpressure downstream

The downstream check valve (B) closes, preventing contaminated water from flowing into the main supply.

If the downstream check valve is not perfectly sealed, the contaminated water can seep into the central chamber; the pressure in the central chamber increases, causing the shutter to open, discharging contaminated water.

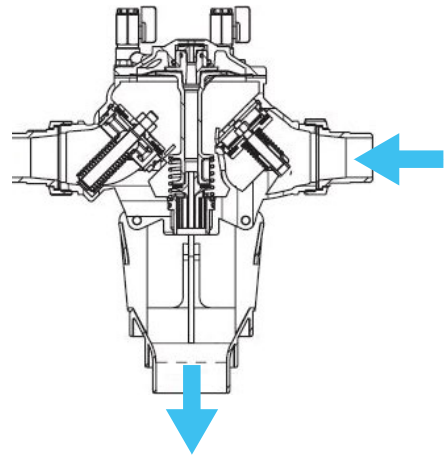

Flow with anomalies: depression upstream (siphoning)

If the pressure upstream accidentally decreases, the check valves (A and B) automatically close; this way the difference in pressure between the upstream area and the central area is cancelled; the return force of the spring causes the shutter to open, emptying the central area.

This interrupts the flow between the upstream and downstream zones, ensuring complete safety.

The emptying of the central area causes the decrease in pressure. It brings the devices back to the initial safe condition.

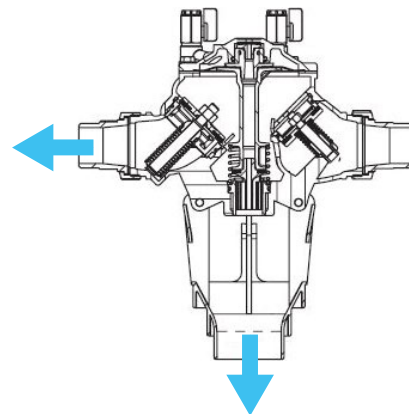

Installation

As prescribed by standard UNI EN 12729, the installation requirements for BA type preventers are:

- the device must be easily accessible;
- the device must not be installed in locations that could be subject to flooding;
- the device must be installed in a ventilated environment (non-polluted atmosphere),
- the discharge must be able to receive discharge inflow;
- it must be protected against freezing or excessive temperatures;
- it must be installed in a horizontal position, with the opening of the discharge valve facing down. The pressure cocks must allow for inspection tests without difficulty;
- it may be installed only for potential backflow not exceeding the discharge capacity of the protection device.

Before installing the backflow preventer, let an abundant quantity of water flow to remove impurities (it may be possible to install a filter upstream of the device to retain the impurities that may deteriorate the sealing seats of the check valves).

Ensure that there is sufficient space around the preventer so that the test valves are easily accessible for checks and maintenance.

The drain must be facing down, at least 30 cm above the drain surface of the underlying stream, and it must be connected to pipes leading to the sewage system.

The table shows the minimum sections recommended for collecting water to be evacuated.

DN OF PREVENTER	DN15 (1/2")	DN20 (3/4")	DN25 (1")	DN32 (1-1/4")	DN40 (1-1/2")	DN50 (2")	DN65	DN80	DN100	DN150
DN OF EVACUATION NETWORK	50	63					75 / 90 / 120			

Threaded versions

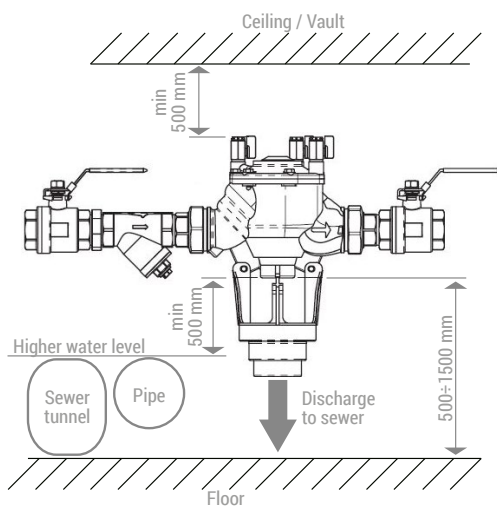

Flanged versions

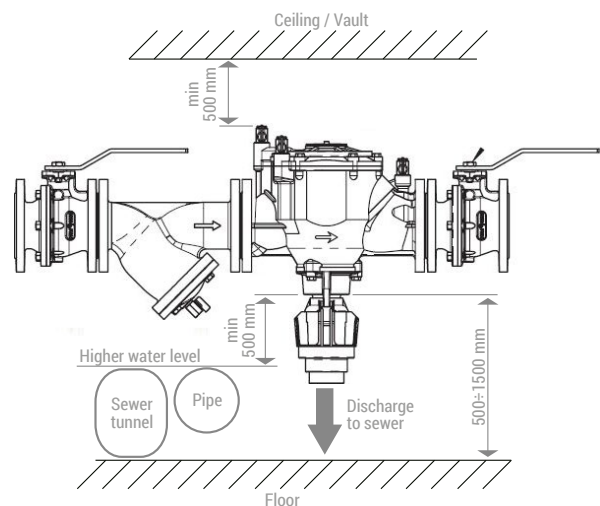

Commissioning

The two shut-off valves should initially be closed.

Slowly open the inlet valve until the backflow preventer is fully pressurised: at this point, bleed the air by slightly opening each of the control cocks.

Slowly open the outlet valve: this puts the device into operation.

If the discharge valve shows intermittent discharges (due to the fluctuation of pressure or water hammers in the system) it is advisable to install pressure reducing valves or anti-water hammer valves.

➤ Applications

Based on the standard UNI EN 1717, the R626 preventer falls under the BA category, where B represents the protection family (controllable disconnection) and A is the type of protection of that family (vacuum breaker with controllable reduced pressure zone).

The fluids from which protection is required are divided into categories based on their use (UNI EN 1717).

Standard UNI EN 12729 defines the application field and size, chemical/physical and mechanical characteristics of the controllable backflow preventer with different pressure zones - family B, type A.

Based on this standard, the R626 preventer provides protection from fluids in categories 1, 2, 3 and 4. For fluids in category 5 it is necessary to install an hydraulic separation tank.

1	WATER DESTINED FOR CONSUMPTION	CATEGORY
1.1	Drinking water	1
1.2	High pressure water	1
1.3	Stagnant water	2
1.4	Iced water	2
1.5	Hot sanitary water	2
1.6	Steam (in contact with foodstuffs; additive-free)	2
1.7	Purified water (inside buildings)	2
2	WATER WITH ADDITIVES, OR IN CONTACT WITH LIQUID OR SOLID ELEMENTS OTHER THAN THOSE IN CATEGORY 1	CATEGORY
2.1	Softened water not destined for human consumption	3 4*
2.2	Water + anti-corrosive, not destined for human consumption	3 4*
2.3	Water + antifreeze	3 4*
2.4	Water + algicide	3 4*
2.5	Water + liquid foodstuffs	2
2.6	Water + solid foodstuffs	2
2.7	Water + alcoholic drinks	2
2.8	Water + cleaning products	3 4*
2.9	Water + surface-active products	3 4*
2.10	Water + disinfectants not destined for human consumption	3 4*
2.11	Water + detergents	3 4*
2.12	Water + coolant	3 4*

3	WATER COMING FROM OTHER USES	CATEGORY
3.1	Water for cooking food	2
3.2	Water used for cleaning fruit and vegetables (catering system)	3 5**
3.3	Water for pre-washing and washing dishes and cooking utensils	5
3.4	Water for rinsing dishes and cooking utensils	3
3.5	Water from the central heating system, without additives	3
3.6	Refluent water from sewers	5
3.7	Water used for personal hygiene	5
3.8	Water from the toilet tank	3
3.9	Water from the toilet	5
3.10	Drinking water for animals	5
3.11	Water for swimming pools	5
3.12	Water used for cleaning clothes	5
3.13	Sterilised water	2
3.14	Demineralised water	2

(*) the boundary between categories 3 and 4 refers to the EU Directive 93/21/EEC of 27/04/1993.

(**) category 5 for water for pre-washing and washing - category 3 for rinsing water.

➤ Dimensions

Threaded versions

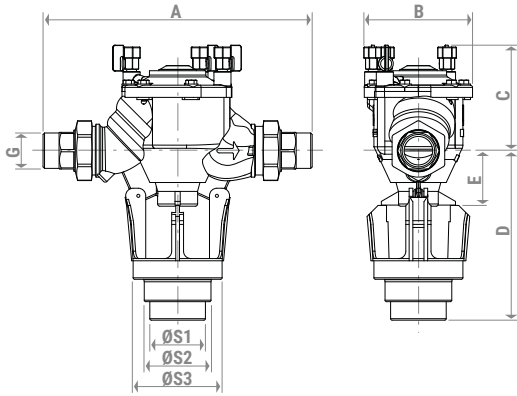

CONNECTIONS	DN	G	A [mm]	B [mm]	C [mm]	D [mm]	E [mm]	ØS1 [mm]	ØS2 [mm]	ØS3 [mm]
R626Y003	15	G 1/2"M	174	68	58	169	58	50	-	-
R626Y004	20	G 3/4"M	258	106	107	186	55	63	-	-
R626Y005	25	G 1"M	258	106	107	186	55		-	-
R626Y006	32	G 1-1/4"M	357	146	140	230	75	75	91	96
R626Y007	40	G 1-1/2"M	357	146	140	230	75			
R626Y008	50	G 2"M	428	181	159	243	88			

Flanged versions

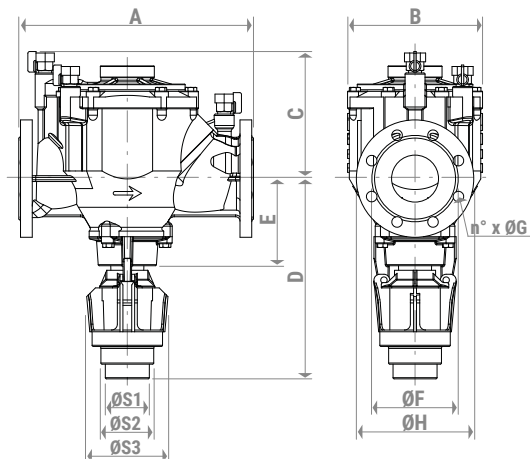

CONNECTIONS	DN	N° x ØG	ØF [MM]	ØH [MM]	A [mm]	B [mm]	C [mm]	D [mm]	E [mm]	ØS1 [mm]	ØS2 [mm]	ØS3 [mm]
R626Y106	65	4x18	160	185	360	189	200	290	137	75	90	120
R626Y108	80	8x18	185	200	400	230	214	341	157			
R626Y110	100	8x18	200	220	450	230	234	347	163			
R626Y115	150	8x22	210	250	540	276	259	370	186			

➤ Product specifications

R626Y003

Backflow preventer with controllable reduced pressure zone. BA type (UNI EN 1717). Protection against fluids of categories 1, 2, 3, 4 (UNI EN 1717). Complies with UNI EN 12729. Threaded connections - 1/2" male with tail piece. Main body and covers in corrosion resistant brass (CR). Max. working temperature 65 °C. Max. working pressure 10 bar. Complete with upstream, intermediate and downstream pressure sockets and relief funnel with fitting collar for pipe.

R626Y004÷008

Backflow preventer with controllable reduced pressure zone. BA type (UNI EN 1717). Protection against fluids of categories 1, 2, 3, 4 (UNI EN 1717). Complies with EN 12729. Threaded connections - 3/4"-2" male with tail piece. Main body and covers in bronze. Max. working temperature 65 °C. Max. working pressure 10 bar. Complete with upstream, intermediate and downstream pressure sockets and relief funnel with fitting collar for pipe.

R626Y106÷115

Backflow preventer with controllable reduced pressure zone. BA type (UNI EN 1717). Protection against fluids of categories 1, 2, 3, 4 (UNI EN 1717). Complies with EN 12729. Flanged connections DN 65÷DN 150 (flange PN10 EN 1092-1). Main body and covers in cast iron GJL250 painted with epoxy enamel. Max. working temperature 65 °C. Max. working pressure 10 bar. Complete with upstream, intermediate and downstream pressure sockets and relief funnel with fitting collar for pipe.

⚠ Safety Warning. Installation, commissioning and periodical maintenance of the product must be carried out by qualified operators in compliance with national regulations and/or local standards. A qualified installer must take all required measures, including use of Individual Protection Devices, for his and others' safety. An improper installation may damage people, animals or objects towards which Giacomini S.p.A. may not be held liable.

♻ Package Disposal. Carton boxes: paper recycling. Plastic bags and bubble wrap: plastic recycling.

ℹ Additional information. For more information, go to giacomini.com or contact our technical assistance service. This document provides only general indications. Giacomini S.p.A. may change at any time, without notice and for technical or commercial reasons, the items included herewith. The information included in this technical sheet do not exempt the user from strictly complying with the rules and good practice standards in force.

♻ Product Disposal. Do not dispose of product as municipal waste at the end of its life cycle. Dispose of product at a special recycling platform managed by local authorities or at retailers providing this type of service.