

R153M

Diaphragm pressure reducer



Energy
Management

Datasheet
0689EN  06/2023



The R153M diaphragm pressure reducer is an automatic valve that reduces and stabilizes the pressure of a fluid in a water distribution conduit according to a preset value.

The use of this hydraulic device is necessary if the maximum possible pressure at any point in the water distribution system can reach or exceed the relative maximum allowable working pressure, or if apparatus and equipment that function exclusively at lower levels of pressure are connectable.

The pressure reducer is made of CR brass which is resistant to dezincification and reduces corrosion in the system to a minimum; even if the local water supply should cause such a phenomenon (likewise ideal in conditions described in EN 806-2 A.1).

The enhanced mechanical strength of the shell and its internal components renders this valve particularly suitable for domestic water installations for water distribution outside buildings (EN 805), where the water pressure in the water mains may reach values as high as 25 bar.

Further, the compensated seat offsets the influence that variations in upstream pressure may have on the downstream pressure. The flexible diaphragm in EPDM rubber is reinforced with high mechanical strength polyamide textile and in conjunction with the O-Ring made of EPDM peroxide rubber, they allow a precise and long-lasting pressure regulation.

The internal finish of the valve's body and the absence of moving parts guarantee an elevated flow capacity, even when the water draw is minimal.

The pressure reducer is used in air conditioning plants, domestic water installations for water supply, irrigation systems, compressed air (not oil mist) distribution systems, domestic water installations for water supply within buildings, according to EN 806-2; and for fire suppression piping (it should nevertheless be borne in mind that local government standards for fire protection must always be observed). This product adheres to the standards set forth by the European health authorities for the transport of alimentary fluids and potable water.

 **NOTE.** The pressure gauge installed on the pressure reducer indicates the outlet fluid reduced pressure.

➤ Versions and product codes

PRODUCT CODE	CONNECTIONS
R153MY003	G 1/2"F
R153MY004	G 3/4"F
R153MY005	G 1"F
R153MY006	G 1-1/4"F
R153MY007	G 1-1/2"F
R153MY008	G 2"F

➤ Technical data

Performance

- Max. working pressure (PN): 25 bar
- Outlet pressure regulation range: 1,5÷7 bar
- Outlet pressure factory set: 3 bar
- Working temperature range: 0÷80 °C (no freezing)
- Compatible fluids: water, glycol solutions (max. 50 %), compressed air only for 1/2", 3/4", 1", 1-1/4", 1-1/2"
- Compliant with Standard EN 1567
- Sound class II - Lap [dB (A)] < 30

Flow rate diagrams

Rated water flow rate, relative to a speed of 2 m/s, for each diameter according to requirements of standard EN 1567.

PRODUCT CODE	CONNECTIONS	FLOW RATE [m³/h]	FLOW RATE [l/min]
R153MY003	G 1/2"F	1,27	21,16
R153MY004	G 3/4"F	2,27	37,83
R153MY005	G 1"F	3,6	60
R153MY006	G 1-1/4"F	5,8	96,66
R153MY007	G 1-1/2"F	9,1	151,66
R153MY008	G 2"F	14	233,33

Accessories

- R225Y002: G 1/4"M rear connection pressure gauge, dial Ø 52 mm, scale 0÷10 bar

Materials

- Body: DZR CW602N brass (UNI EN 12165)
- Diaphragm: EPDM with polyamide reinforcement
- Gaskets: EPDM peroxide (dynamic O-Ring seals), NBR (gaskets, seat and static O-Ring seals)
- Seat: EN 10088 - 1.4305 stainless steel (AISI 303)
- Spring: EN10270-1 SM zinc plated steel

Loss of pressure

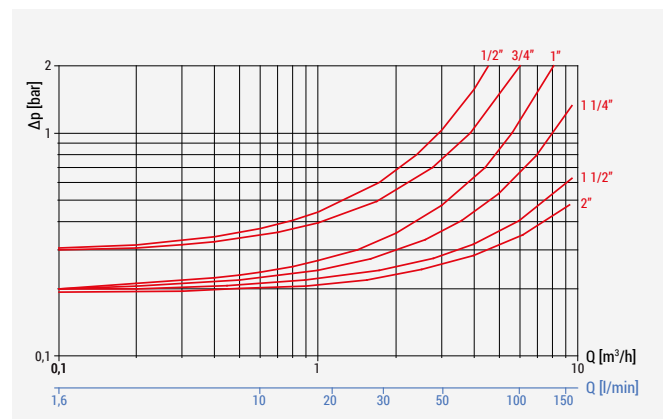

➤ Operation

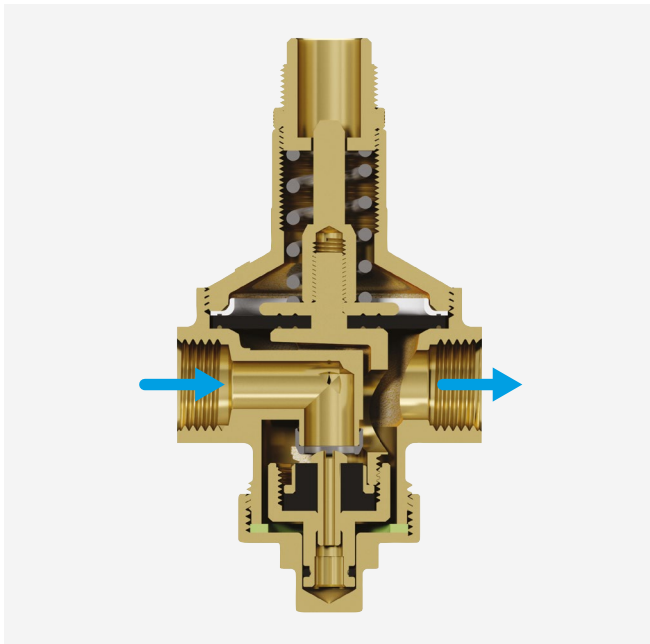

A flexible diaphragm actuates the stopper movement, as consequence from the two opposing forces: water pressure from the bottom in the pipe downstream from the reducer (which tends to close the valve), pushing from the top by an appropriately loaded spring in relation to the work pressure in play (tends to open the valve).

The valve opens when, following flow rate request, pressure beneath the diaphragm decreases and spring pushing action prevails; valve opening is proportional to the instantaneous flow that crosses it.

Once the flow is shut, as soon as the water contained in the pipe downstream reaches a pressure able to overcome the pushing action of the return spring, the stopper rises to close the valve.

The regulation pressure is obtained by screwing the regulator that applies more or less compression to the spring.

The compensated seat that the Giacomini pressure reducers are equipped with, makes possible to keep set value steady even with strong inlet pressure variations: the upstream pressure pushes the stopper in the open position, but also pushes the compensation chamber pin in the opposite direction, obtaining a substantial balance.

The inserted seal seat, in stainless steel, guarantees long-term reliability and accuracy of the pressure reducer, even in the most extreme working conditions.

➤ Installation

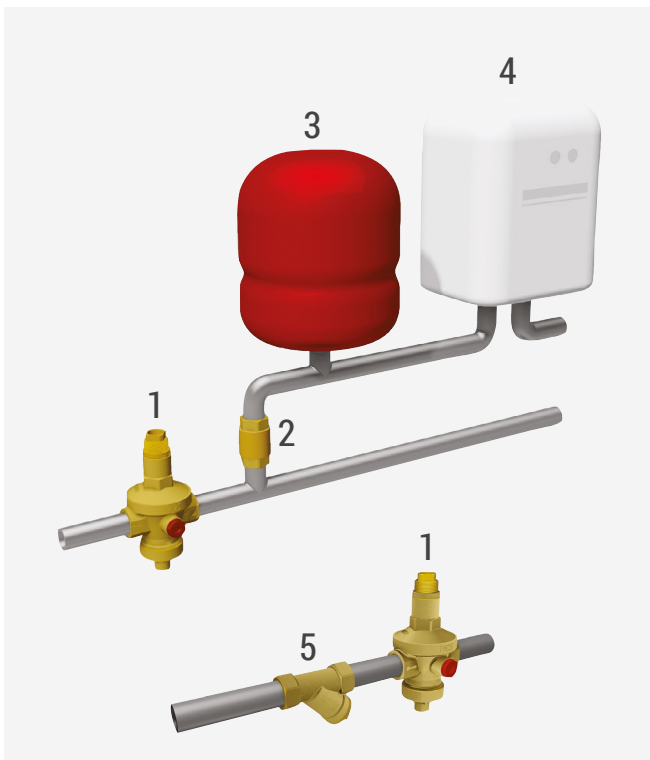

We recommend to install a filter before the reducer to eliminate all impurities in the water that may deposit onto the reducer seat and cause malfunctions.

When installing the pressure reducer at the inlet of boilers, hot water heaters, furnaces or hot water tanks, a plumbing expansion tank must be fitted after the reducer even if a check valve is already installed.

- | | |
|---|-------------------------|
| 1 | Pressure reducer, R153M |
| 2 | Disc check valve |
| 3 | Expansion tank |
| 4 | Boiler |
| 5 | Filter |

➤ Dimensions

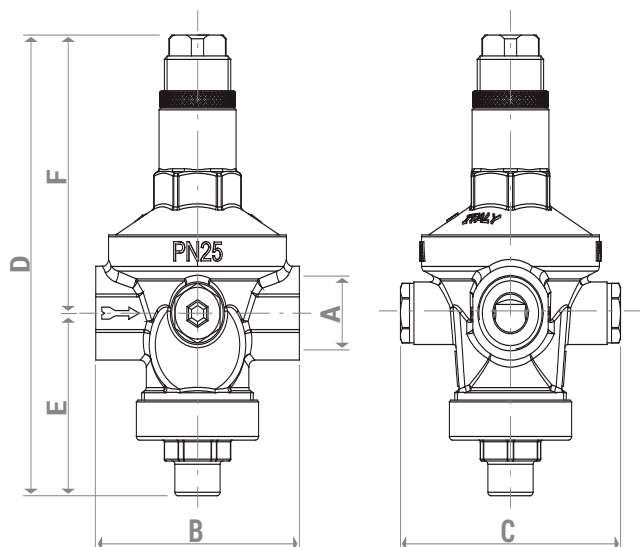

PRODUCT CODE	CONNECTIONS A	B [mm]	C [mm]	D [mm]	E [mm]	F [mm]
R153MY003	G 1/2"F	67,5	73	132,5	52,5	80
R153MY004	G 3/4"F	77	73	156	65,5	90,5
R153MY005	G 1"F	90	87	190	69,5	120,5
R153MY006	G 1-1/4"F	106	99	197	74	123
R153MY007	G 1-1/2"F	137	104	241	82,1	158,9
R153MY008	G 2"F	170	117	266,8	87	179,8

➤ Product specifications

R153M

Diaphragm pressure reducer with compensated seat in stainless steel compliant to standard EN 1567. Female-Female G 1/2"÷ G 2" threaded connections. Pressure gauge connection Rp 1/4". Body in "CR" brass, diaphragm in reinforced EPDM with polyamide, EPDM and NBR gaskets. Compatible fluids: water, glycol solutions (max. 50 %), compressed air only for 1/2", 3/4", 1", 1-1/4", 1-1/2". Max. working temperature 80 °C. Max. working pressure 25 bar. Outlet pressure regulation range from 1,5 to 7 bar:

⚠ Safety Warning. Installation, commissioning and periodical maintenance of the product must be carried out by qualified operators in compliance with national regulations and/or local standards. A qualified installer must take all required measures, including use of Individual Protection Devices, for his and others' safety. An improper installation may damage people, animals or objects towards which Giacomini S.p.A. may not be held liable.

♻ Package Disposal. Carton boxes: paper recycling. Plastic bags and bubble wrap: plastic recycling.

ℹ Additional information. For more information, go to giacomini.com or contact our technical assistance service. This document provides only general indications. Giacomini S.p.A. may change at any time, without notice and for technical or commercial reasons, the items included herewith. The information included in this technical sheet do not exempt the user from strictly complying with the rules and good practice standards in force.

♻ Product Disposal. Do not dispose of product as municipal waste at the end of its life cycle. Dispose of product at a special recycling platform managed by local authorities or at retailers providing this type of service.