

# R146C



Energy  
Management

## Adjustable magnetic dirt separator

Datasheet  
0840EN 02/2023



PATENTED



R146CX004/005

R146CX006



© VIDEO

Point the QR-Code with  
your smartphone or tablet  
to view the video tutorial.

The R146C adjustable magnetic dirt separator separates and removes debris inside hydraulic circuits of modern HVAC systems. Impurities are separated by the combined action of water centrifugal force, a magnet and a metal filter.

They can be then discarded by the drain cock.

The special adjustable fitting enables to install the dirt separator under-boiler, on horizontal, vertical, angled and also 90°-angled pipes.

### ➤ Versions and product codes

PRODUCT CODE	CONNECTIONS	COMPONENTS INCLUDED
R146CX004	G 3/4"M	<ul style="list-style-type: none"><li>Adjustable 3-way inlet/outlet fitting</li><li>Cap for inlet/outlet fitting</li></ul>
R146CX005	G 1"M	<ul style="list-style-type: none"><li>Adjustable drain cock G 1/2"M x G 3/4"F</li><li>Magnet with brass housing</li></ul>
R146CX006	G 1-1/4"F	<ul style="list-style-type: none"><li>Adjustable 2-way inlet/outlet fitting</li><li>Adjustable drain cock G 1/2"M x G 3/4"F</li><li>Magnet with brass housing</li></ul>

#### Optionals for R146CX004

- R254PY034: shut-off ball valve, G 3/4"F flat seat nut x G 3/4"M
- R176PY008: tail piece, G 3/4"F flat seat nut x G 3/4"F
- R176PY018: adjustable tail piece, G 3/4"F flat seat nut x G 3/4"F

#### Optionals for R146CX005

- P15FY005: pair of two tail pieces, G 1"F flat seat nut x Rp 1"

## Technical data

- Fluid: water, glycol-based solutions (max. 50 % of glycol)
- Temperature range: 5+90 °C
- Max. inlet pressure: 10 bar
- Filter: 300 µm
- Magnetic capacity: 13000 Gauss (red magnet)

NOTE. For use with higher temperatures and/or pressures, replace the drain cock with a brass plug (code R92X003).

### Materials

- Body: nickel plated brass CW617N - UNI EN 12165
- Inlet/outlet fitting for R146CX004/005: nickel plated brass CW617N - UNI EN 12165
- Inlet/outlet fitting for R146CX006: nickel plated brass UNI EN1982 CB753S
- Cyclonic chamber: nylon 66 glass-filled 30 % (PA66GF30)
- Filter: AISI 304 stainless steel
- Gaskets: EPDM
- Magnet: neodymium (N42H) (red magnet)

### Losses of pressure

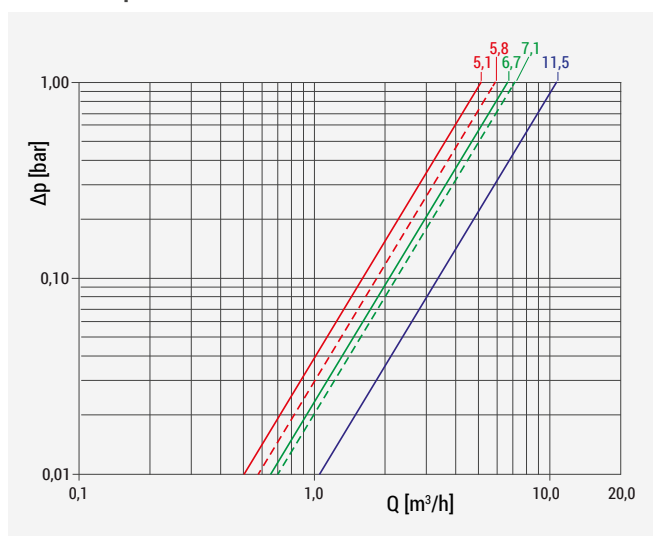

CONFIGURATION	CURVE ON THE GRAPH	Kv
<b>In-line pipes</b>		
	R146CX004 (3/4")	5,1
	R146CX005 (1")	6,7
	R146CX006 (1-1/4")	11,5
<b>90°-angled pipes</b>		
	R146CX004 (3/4")	5,8
	R146CX005 (1")	7,1

## Components

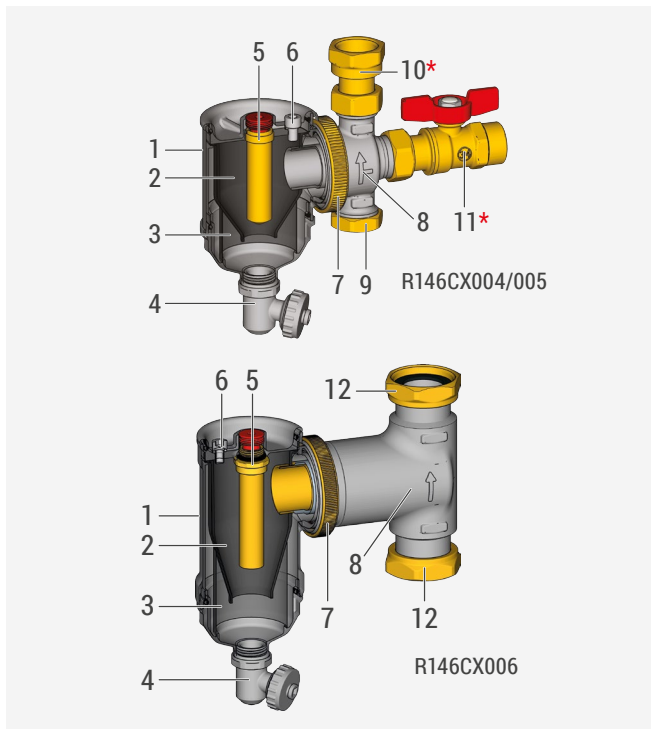

- 1 Dirt separator body
- 2 Cyclonic chamber
- 3 Filter
- 4 Adjustable drain cock
- 5 Magnet housing and magnet
- 6 Air vent screw
- 7 Fitting lock nut
- 8 Adjustable inlet/outlet fitting
- 9 Cap
- 10 Flat seat tail piece **\*(Optional)**
- 11 Shut-off ball valve **\*(Optional)**
- 12 Flat seat nuts with gaskets

## Operation

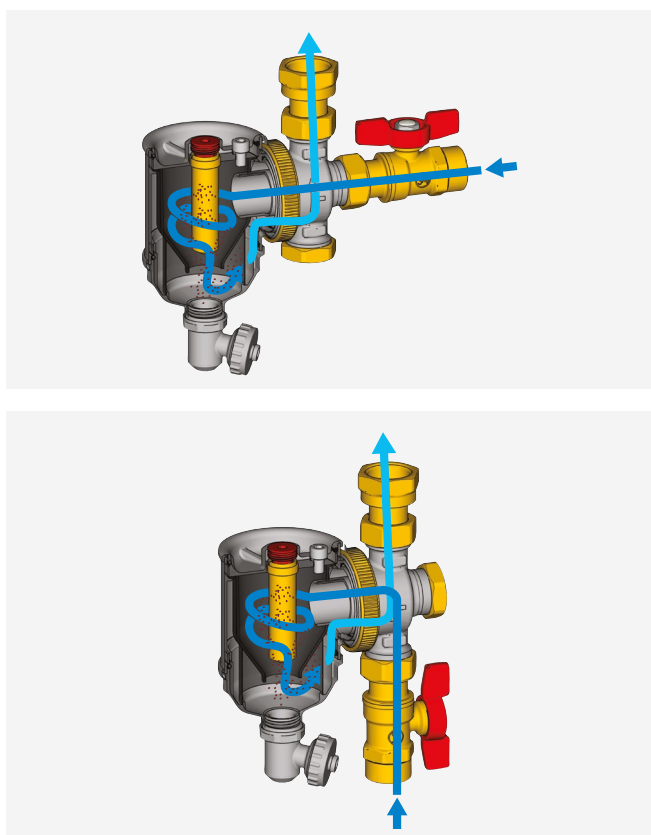

- Impure water flowing into the dirt separator
- Impurity-free water flowing out from the dirt separator

The water flows into the dirt separator and is then channeled into the cyclonic chamber where a vortical motion enhances particle separation; this area also features a magnet that retains metal impurities.

A metal filter below the cyclonic chamber holds the impurities decanting from the chamber itself on the bottom of the separator.

The dirt separator features a screw on top which releases air upon initial operation (see "Installation" paragraph).

The separator can be cleaned without being disassembled and/or switching off the system by opening the drain cock on the bottom of the separator (see "Maintenance" paragraph).

## Installation

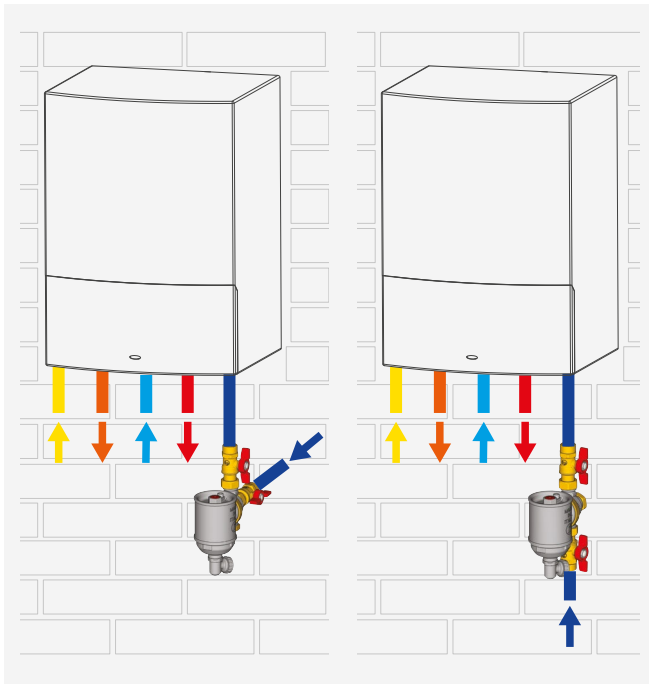

— Heating system return

— Heating system delivery

— Domestic cold water

— Domestic hot water

— Gas supply

In order to protect the boiler from the impurities in the heating system, the dirt separator must be installed on the heating return circuit.

The 3/4" and 1" versions, thanks to their compact size enable to install them right under a wall-mount boiler.

The 1-1/4" version, thanks to the greater water flow, is used in heat pump systems.

Leave a free space on the upper side of the separator, at least 50 mm, to easily remove the magnet.

**NOTE.** To facilitate maintenance operations, it is recommended to install a shut-off valve upstream and downstream of the R146C dirt separator.

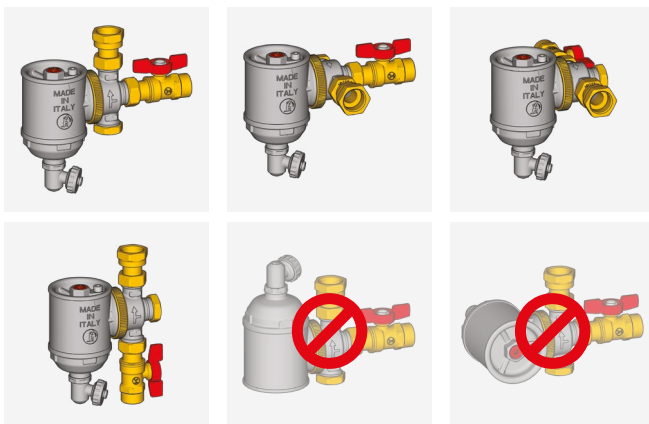

Loosen the ring nut (Components - Ref.7) to adjust the orientation of the outlet/inlet fitting (Components - Ref.8), place the fitting in the desired position and tight the ring nut. Connect one inlet and the outlet of the inlet/outlet fitting to the heating system and screw the cap included with the dirt separator (only for 3/4" and 1" versions), on the unused inlet. The main body should always be in vertical position with the drain facing down.

**WARNING.** The dirt separator is equipped with a magnet that causes magnetic fields  $\text{U}$ , which may damage electronic devices (pacemakers included  $\text{H}$ ) near the circuit.

### Air vent screw



On top of the dirt separator is a screw to vent air from the system during the start-up (Components - Ref.6).

Release the air by turning the screw in counterclockwise direction with a 5 mm Allen wrench.

Tighten the screw clockwise once the air has been removed.

## ➤ Maintenance

### How to clean the dirt separator

During system operation, impurities collect on the surface of the magnet housing and on the bottom of the dirt separator. The dirt separator requires no shutting off and disassembling to be cleaned; **however we recommend carrying out these operations with no flow inside the dirt separator.**

To clean the separator and remove impurities, follow the steps below:

- 1) close the shut-off ball valves upstream and downstream the dirt separator;
- 2) pull out the magnet from its housing by unscrewing it in counterclockwise direction with a 5 mm Allen wrench; the impurities collected on the housing surface will deposit on the bottom of the separator;
- 3) after a few minutes, take the cap from the drain cock, and place it on the bottom of the cock, then rotate counterclockwise to open the drain cock and discharge the impurities in the dirt separator;
- 4) once the impurities have been removed, close the drain cock and reinsert the magnet in its housing, screwing it in clockwise direction;
- 5) open the shut-off ball valves upstream and downstream the dirt separator and restore the normal operation.

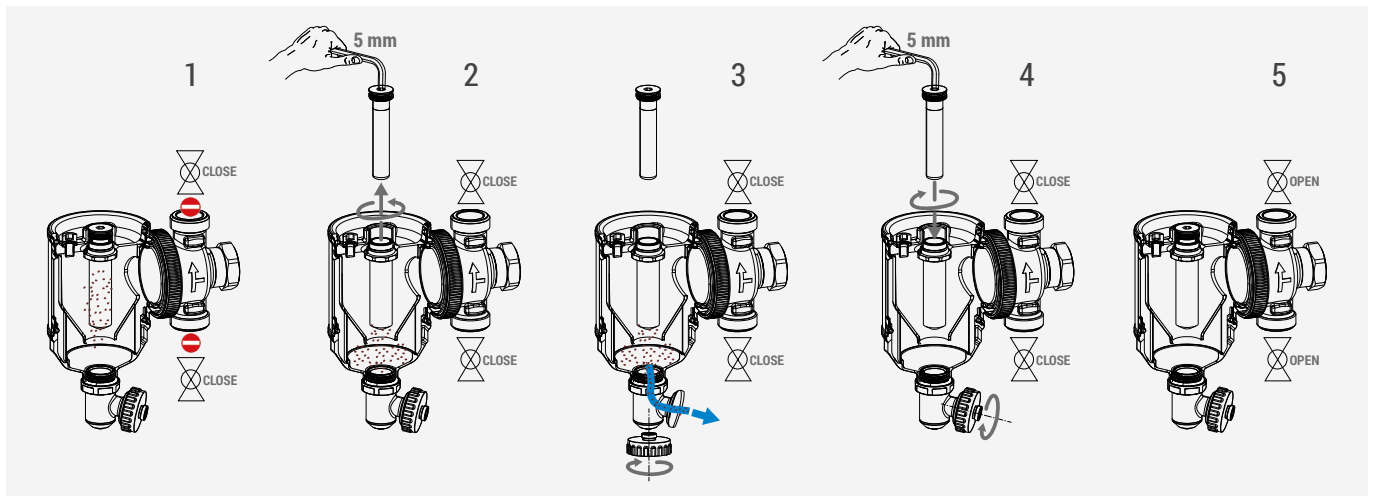

### How to clean the metal filter (Components - Ref.3)

For a more thorough cleansing, proceed as follows:

- 1) turn off the system and close the shut-off ball valves upstream and downstream the dirt separator;
- 2) unscrew the dirt separator base in counterclockwise direction;
- 3) remove the filter from the dirt separator and wash it under running water;
- 4) fit the filter back in and screw the separator back on its base.
- 5) open the shut-off ball valves upstream and downstream the dirt separator and restore the normal operation.

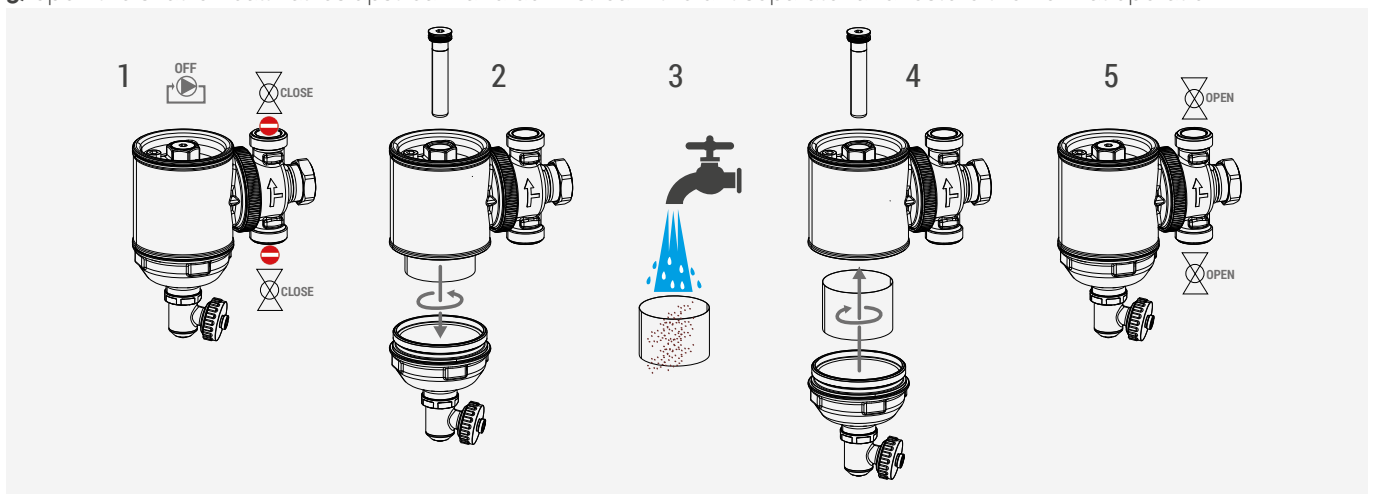

**▲ WARNING.** Install an air vent valve on the system circuit to release the air after servicing and cleaning the components.

## ➤ Dimensions

### R146CX004/005

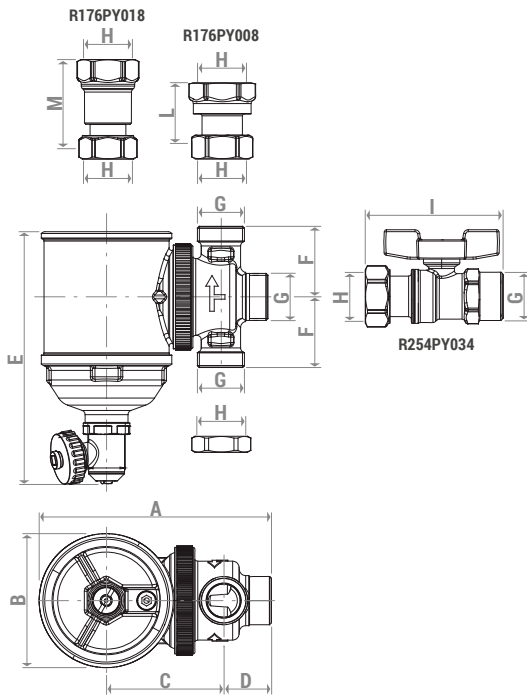

### R146CX006

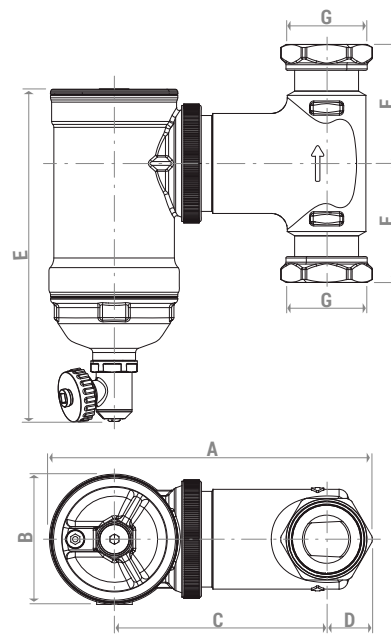

PRODUCT CODE	A [mm]	B [mm]	C [mm]	D [mm]	E [mm]	F [mm]	G [mm]	H [mm]	I [mm]	L [mm]	M [mm]
R146CX004	126,5	73	64	26	141	39,5	3/4" M	3/4" F	75	33	49÷62
R146CX005	139	73	70	33	187	43	1" M	1" F	-	-	-
R146CX006	181	73	119	26	187	67	1-1/4" F	-	-	-	-

## ➤ Product specifications

### R146CX004/005

Adjustable magnetic dirt-separator, equipped with 3-way inlet/outlet fitting with G 3/4" M or G 1" M connections, G 3/4" F or G 1" F cap, adjustable drain cock and brass magnet housing. Nickel plated brass body CW617N - UNI EN 12165. Cyclonic chamber made of synthetic material. Filter 300 µm. Neodymium magnet N42H. Magnetic capacity: 13000 Gauss (red magnet). EPDM gaskets. Temperature range 5+90 °C. Max. working pressure 10 bar. Fluid: water, glycol-based solutions (max. 50 % of glycol).

### R146CX006

Adjustable magnetic dirt-separator, equipped with 2-way inlet/outlet fitting with G 1-1/4" F connections, adjustable drain cock and brass magnet housing. Nickel plated brass body CW617N - UNI EN 12165. Cyclonic chamber made of synthetic material. Filter 300 µm. Neodymium magnet N42H. Magnetic capacity: 13000 Gauss (red magnet). EPDM gaskets. Temperature range 5+90 °C. Max. working pressure 10 bar. Fluid: water, glycol-based solutions (max. 50 % of glycol).

**⚠ Safety Warning.** Installation, commissioning and periodical maintenance of the product must be carried out by qualified operators in compliance with national regulations and/or local standards. A qualified installer must take all required measures, including use of Individual Protection Devices, for his and others' safety. An improper installation may damage people, animals or objects towards which Giacomini S.p.A. may not be held liable.

**♻ Package Disposal.** Carton boxes: paper recycling. Plastic bags and bubble wrap: plastic recycling.

**ℹ Additional information.** For more information, go to [giacomini.com](http://giacomini.com) or contact our technical assistance service. This document provides only general indications. Giacomini S.p.A. may change at any time, without notice and for technical or commercial reasons, the items included herewith. The information included in this technical sheet do not exempt the user from strictly complying with the rules and good practice standards in force.

**♻ Product Disposal.** Do not dispose of product as municipal waste at the end of its life cycle. Dispose of product at a special recycling platform managed by local authorities or at retailers providing this type of service.