

**KDV VRAY500**

**Description**

KDV are monoblock units for ceiling installation and use with air treatment radiant systems. These are duct-type devices for ventilation, dehumidification and sensitive power integration.

A KDV VRAY500 unit connected to a radiant panel system can perform air treatment based on season and room comfort needs, thanks to the functions listed below:

- air exchange, both in winter and summer, with heat recovery
- air exchange with no heat recovery (free-cooling)
- summer dehumidification with control of delivery air temperature
- dehumidification-free summer cooling through radiant system water
- winter air heating through radiant system hot water

The machine is made from a zinc-plated sheet structure that collects: a direct expansion refrigeration circuit and an alternative refrigeration compressor, a coil with fins fed from the hydraulic circuit of the radiant system, a high-efficiency air/air heat recovery, two dampers (one optional) to regulate the aerulic flows and two electronically controlled EC fans.

Thanks to the particular fans used, the machine's electronic controller allows the user to set the air flow rate in the various functions: the unit will achieve these flow rates regardless of the pressure drop of the air ducts, provided these do not exceed the maximum pressure available.

**Versions and product codes**

Product code	Dehumidification	Cooling integration	Ventilation	Technical communication ref.
KDV VRAY360	YES	YES	YES	0935EN
<b>KDV VRAY500</b>	<b>YES</b>	<b>YES</b>	<b>YES</b>	<b>0942EN</b>

**Technical data**

TECHNICAL DATA	
Power supply	230 V 1 Ph 50 Hz
Weight	105 kg
Total condensation capacity (external air 35 °C, 50 % R.H.)	74,1 l/24h 2090 W
Condensation capacity on recirculation (external air 26 °C, 55 % R.H.)	31,2 l/24h 880 W
Cooling capacity on recirculation (external air 26 °C, 55 % R.H.)	2580 W
Rated electrical compressor power	780 W
Water flow rate	500 l/h
Pre-cooling water pressure drop	11 kPa
Max. cooling capacity for water circuit (external air 35 °C, 50 % U.R., max. flow rate for delivery and intake)	2050 W
Power consumption of the delivery fan	min 20 W; max 160 W
Inlet fan air flow rate	min 160 m³/h; max 500 m³/h
Available pressure, inlet fan	260 Pa
Power consumption of the discharge fan	min 20 W; max 160 W
Discharge fan air flow rate	min 160 m³/h; max 500 m³/h
Available pressure, discharge fan	260 Pa
Energy recover, winter (20 °C, 50 % RH internal / -5 °C, 80 % RH external)	Flow rate 160 m³/h - efficiency 91,7 % Flow rate 300 m³/h - efficiency 87,5 %
Energy recover, summer (26 °C, 65 % RH internal / 35 °C, 50 % RH external)	Flow rate 160 m³/h - efficiency 86,7 % Flow rate 300 m³/h - efficiency 80,4 %
Acoustic rating at 1,5 m open field	48 dB(A)

**Main components**

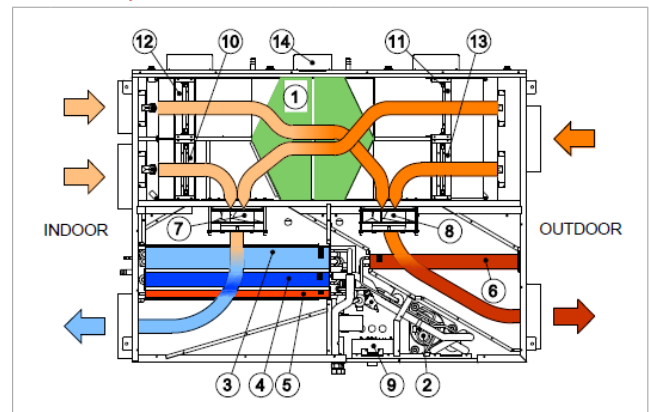

LEGEND			
1	Heat recovery exchanger	8	Discharge fan
2	Compressor	9	In key
3	Water coil	10	Ambient air recirculation damper
4	Evaporator coil	11	Fresh air intake damper
5	Condensing coil	12	Stale air intake damper
6	Condensing coil for external heat transfer	13	Supplementary air intake damper
7	Inflow fan	14	Recuperator by-pass damper

Figure 1 - Components

**Aeraulic operation**

The flow rates of air treated by the unit can be set through the control panel. The fans set automatically on the speed required to overcome the pressure drops in the ducts.

The unit can feature two air flows: an exchange flow with heat recovery through the air/air counterflow recuperator (1) and one for room air recirculation.

The exchange and recirculation flows can be/not be combined based on the flow rates and type of treatment desired for the air entering the system.

It also includes a duct controlled by a motorized damper which enables to intake external air without passing through the recuperator.

This allows to exploit, if available, free cooling from the external air.

The by-pass turns ON automatically when there is a proper input signal and the external temperature is within the limits set.

The following types of air treatment can be performed:

- air exchange with high-efficiency heat recovery and possible winter heating or summer cooling
- free-cooling air exchange, that is with no heat recovery, both in summer and winter
- winter air recirculation, with possible heating
- summer air recirculation, with cooling, dehumidification or cooling and dehumidification
- air recirculation with exchange air, together with all treatments provided for recirculation

The air flow rates may feature the values below:

- air introduced in room, flow rate setting 300 m<sup>3</sup>/h - 500 m<sup>3</sup>/h
- air exchange, flow rate setting 160 - 300 m<sup>3</sup>/h
- free-cooling, exchange flow rate setting 160 - 300 m<sup>3</sup>/h

**Refrigerating circuit operation**

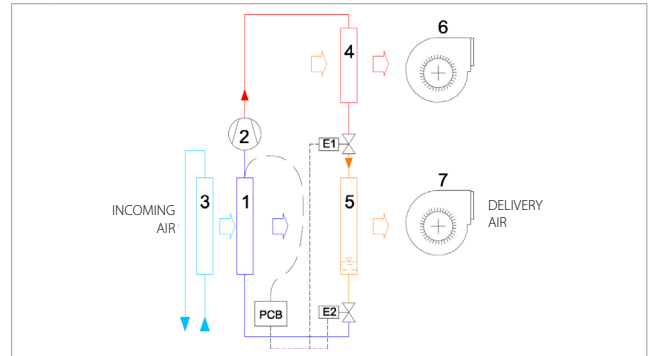

LEGEND			
1	Cooling evaporator	5	Freon/air condenser
2	Cooling compressor	6	Air exhaust fan
3	Water finned coil	7	Air supply fan
4	Excess heat discharge condenser	PCB	Printed circuit board
		E1-2	Electronic expansion valve

Figure 2 - Thermal hygrometric operation

**Cooling**

The finned coil (3), connected to the radiant hydraulic system, provides summer cooling or winter heating.

The output temperature control is performed by the unit itself through the mixing valve installed in the water circuit.

**Dehumidification and cooling**

The finned coil (3) supplied by the radiant system water pre-cools air, while the cooling evaporator (1) carries out subsequent cooling and consequent dehumidification of the air.

The refrigerating circuit includes two parallel-connected condensers: in addition to the air-cooling condenser (5), a second condenser cooled by the ejected air flow (6) disposes of the condensation heat in the external environment. When performing this operation, the unit exploits both the ejected foul air and an additional integration flow of external air.

The two electronic expansion valves (E) enable to distribute the condensation heat in the desired ratio between introduced air and ejected air; in this way, one can obtain the desired temperature for the ejected air between maximum cold and neutral.

The setting values for the ejected air temperature are:

- summer neutral temperature
- summer integration temperature
- winter neutral temperature
- winter integration temperature



**Note:**  
The cooling circuit cannot be turned on in winter nor in the exchange-only function.

**Summer operation**

**EXCHANGE ONLY**

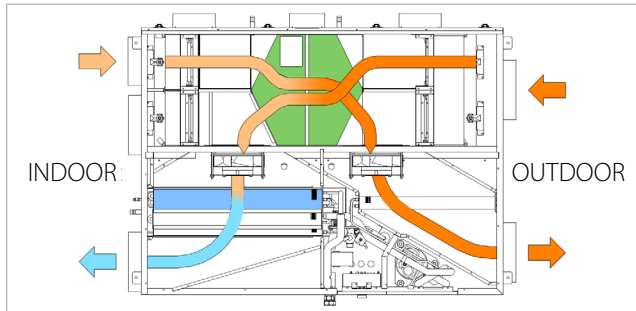

Both fans are ON and provide air exchange: the external air is cooled first by the recuperator through the ejected air, and then by the refrigerated water of the finned coil.

**Winter operation**

**EXCHANGE ONLY**

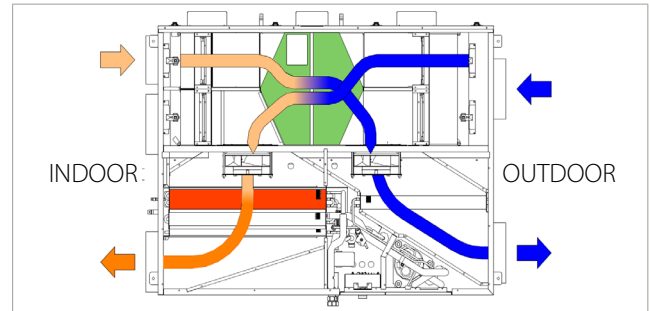

Both fans are ON and provide exchange; the external air is heated first by the recuperator through the ejected air, and then by the hot water circulating inside the finned coil.

**DEHUMIDIFICATION ONLY**

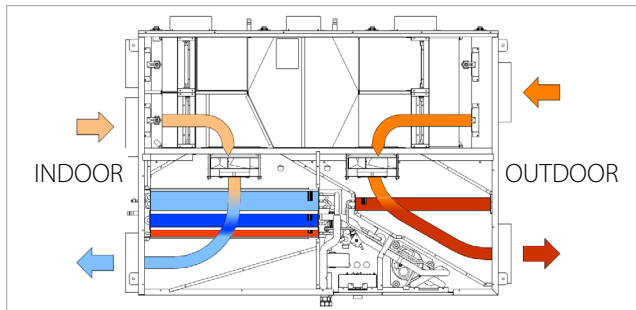

The compressor and delivery fan are ON; the room air is dehumidified and transferred at the temperature setting. Should it be necessary to dispose of the heat in excess, the ejection fan intakes and ejects an external air flow, heated by the disposal coil.

**RECIRCULATION ONLY**

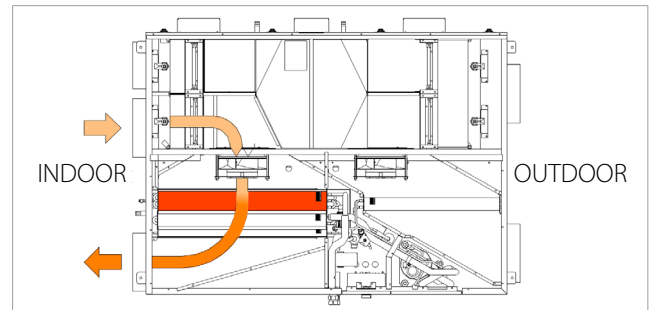

The delivery fan is ON; the room air is sucked and reintroduced at the temperature setting. The ejected air temperature can be set by modulating the hot water flow rate in the finned coil. The flow rate of the introduced air can be set between 300 - 500 m<sup>3</sup>/h

**EXCHANGE + DEHUMIDIFICATION / EXCHANGE + COOLING**

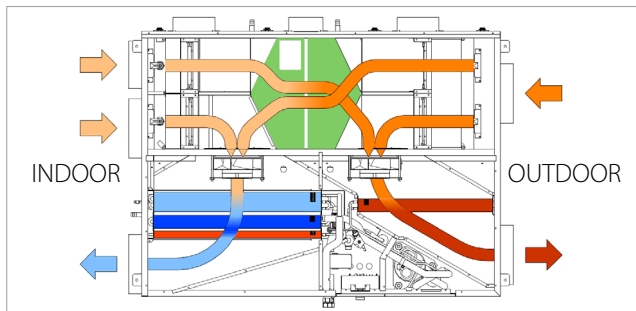

The compressor and both fans are ON. The introduced air is treated by the entire coil pack. The introduced air flow rate can be set between 300 - 500 m<sup>3</sup>/h, while the exchange air can be set between 160 - 300 m<sup>3</sup>/h.

**EXCHANGE + RECIRCULATION**

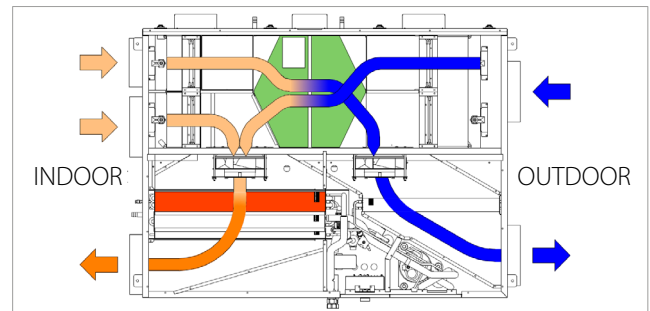

The fans are both ON. The introduced air is heated by the water-powered coil. The exchange air is pre-heated through the recuperator by the ejected air. The introduced air flow rate can be set between 300 - 500 m<sup>3</sup>/h, while the exchange air can be set between 160 - 300 m<sup>3</sup>/h.

**HEAT RECUPERATOR BY-PASS**

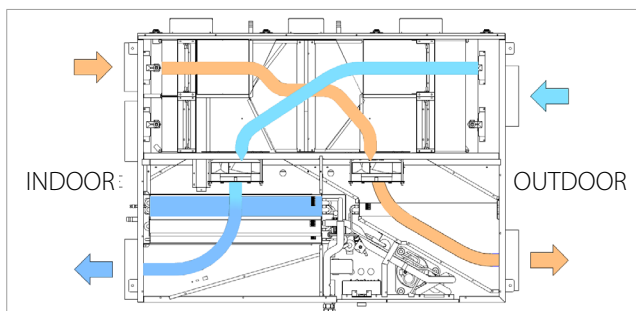

Both fans are ON, the damper of the introduced external air is closed while the bypass damper is open. The introduced air is treated by the refrigerated water coil. The air flow rate can be set between 160 - 300 m<sup>3</sup>/h.

**FREE-COOLING INVERNALE**

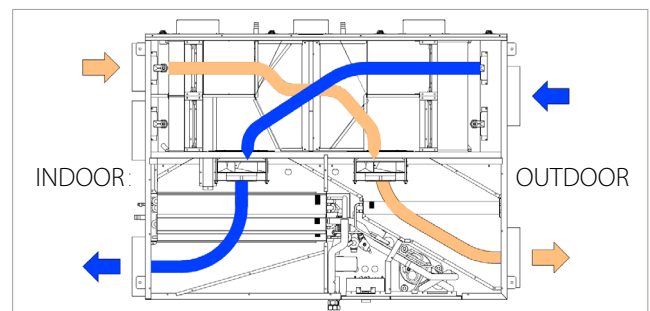

The fans are both ON, the damper of the introduced external air is closed while the by-pass damper is open. The water circuit of the finned coil is closed. The air flow rate can be set between 160 - 300 m<sup>3</sup>/h.

## Control panel

The machine features a remote control panel for installation on DIN template (space occupied by 6 modules) in a wall-mounting electric panel.

The control panel has 3 terminal strips for:

- connection to the unit through four cables that provide electric power to the panel (24 V) and serial communication with the electronic card
- digital input signal for the various functions to be activated
- two digital relay outlets to activate a circulation pump and an alarm in case of malfunction.

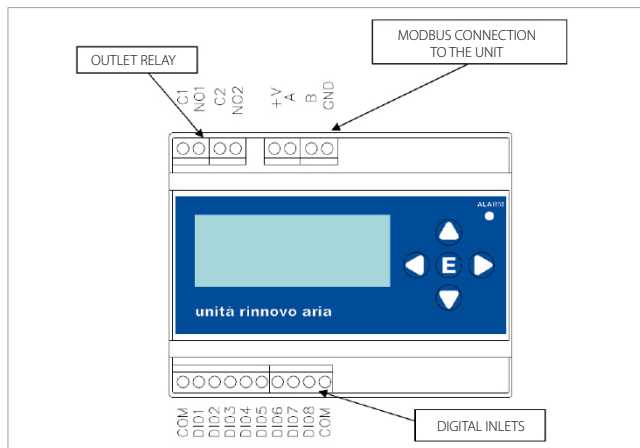

### MODBUS connection

Connection with 4 cables, 2 for 24Vdc power to panel and 2 for serial communication.

Use a screened cable with a 0.5 mm<sup>2</sup> for connection.

### Outlet relays

- C01-NO1: 250V AC – 5A relay which activates when water circulation is required, useful to control a pump
- C01-NO2: 250V AC – 5A relay activated by alarm, useful to provide a remote alarm signal

### Digital inlets

- COM: terminal shared by all inlets
- DI01: season signal, 1 = summer, 0 = winter, if season is set from a digital inlet instead of keypad
- DI02: input signal for room fan activation, this is not an operation mode but enables to keep the room air moving
- DI03: exchange input signal
- DI04: dehumidification input signal
- DI05: cooling input signal in SUMMER or heating input signal in WINTER
- DI06: exchange blocking, enables to block an exchange set with DI03 or with time schedules. This inlet, combined to DI03 and connected to a 3-position selector type 0-1-2, enables operation with three options: exchange ON, exchange OFF, AUTOMATIC exchange with time schedules
- DI07: free-cooling consent (if the external temperature falls within the set range);
- DI08: input signal for flow rate attenuation; this contact enables to reduce the air flow rates without changing the functions active in a specific moment, based on the technical settings. This control is useful when the user wants to turn the unit ON privileging aerial noise reduction versus air conditioning performance, for example during the night

### Funzioni disponibili per il trattamento dell'aria

- **Exchange:** air exchange with flow rate provided for exchange, using heat recuperator
- **Cooling:** it appears when the selected season is summer; the refrigerating compressor is turned ON for dehumidification and the delivery temperature will be the setting value for cooling integration. Cooling can also be performed with refrigerated water only and compressor OFF
- **Heating:** it appears in place of cooling when the selected season is winter; the delivery temperature will be the value for operation with heating integration, achieved through the water-powered coil. The ejected air temperature is controlled by a valve modulating the water flow inside the coil
- **Dehumidification:** the refrigerating compressor is turned ON for dehumidification and the delivery temperature will be the value for operation with neutral air
- **Free-cooling:** it activates air exchange with the flow rate provided for free-cooling, without using the heat recuperator. In addition to the digital input signal, free-cooling requires an external temperature within the technical setting limits
- **Attenuation:** the unit works with the flow rates set for attenuation, which are set by default at lower values compared to normal operation to limit aeraulic noise. This function is useful when the user wants the machine to work during the night

**Connections**

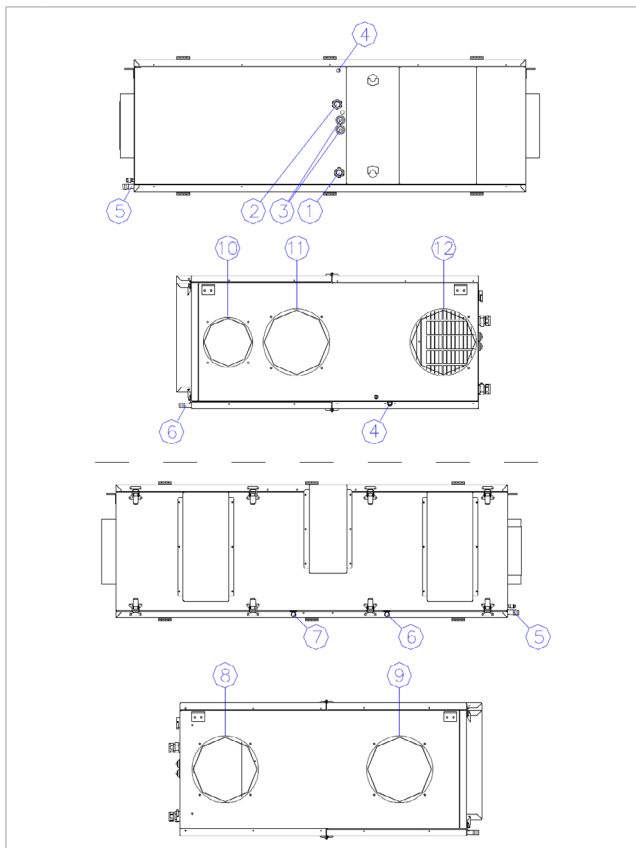

**LEGENDA**

1	Water inlet	7	Summer recovery condensate drain
2	Water output	8	Stale air exhaust
3	Electrical connections	9	Outdoor air intake
4	Hydraulic circuit vent	10	Stale air extract
5	Dehumidifier condensation drain	11	Air recirculation intake
6	Winter recovery condensate drain	12	Air supply to the rooms

Fig. 3 - Connections

**Connection of water circuit pipes**

Shut-off valves must be installed in the refrigerated water pipes to divide the unit system in sections. After connection to the system, check the water seal of both the connections and unit to prevent damages to the room below.

**Condensation drain siphons**

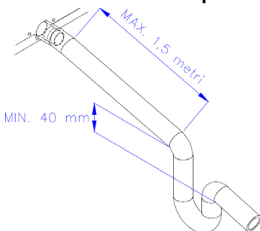

There are two condensation drains, one for summer condensation and one for winter. They must ensure a 15 l/h flow rate and feature a 3% min gradient. Siphons are essential to prevent the air suction from affecting proper drainage of the condensation that may form; they must be independent, with a 40 mm min height difference and installed near the unit drain ducts. Do not directly connect the condensate drains directly into the sewer system because in periods when the machine is not used there could be spread of bad smells.

**Aeraulic connections**

The unit includes plastic nozzles with gaskets, extending for about 4 cm, for installation of flexible or rigid ducts, as long as equipped with gaskets to prevent air leaks and consequent undesired noise.

The nozzle diameters are: delivery and recirculation: Ø 200; exchange and ejection: Ø 200; WC/kitchen foul air intake: Ø 160

The actual diameter of the connections is about 1 mm smaller than the nominal diameter.

**Electric connections**

**Conductor section**

The electric power line and the sectioning devices must be determined by operators qualified for electric network planning; the cable must however feature a 3x1.5 mm<sup>2</sup> min section, F + N+ PE.

The figure below shows the terminals available for the connections:

- electric power must be supplied on the unit edge
- 4-cable connection to control panel; it provides both the panel 24Vdc power and serial communication. This connection cable must have a 0.5 mm<sup>2</sup> min section and be screened.

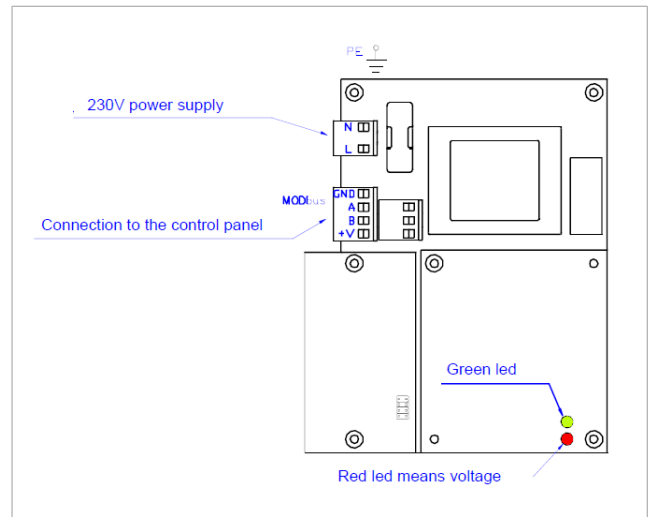

**Connection to control panel**

If the serial communication line between the control panel and the KDV500 unit is longer than 25 m, a 120 Ohm, ¼ W, terminal resistance must be installed between the control panel A and B terminals.

The resistance is fixed with tape on the back of the control panel, in the DIN template notch.

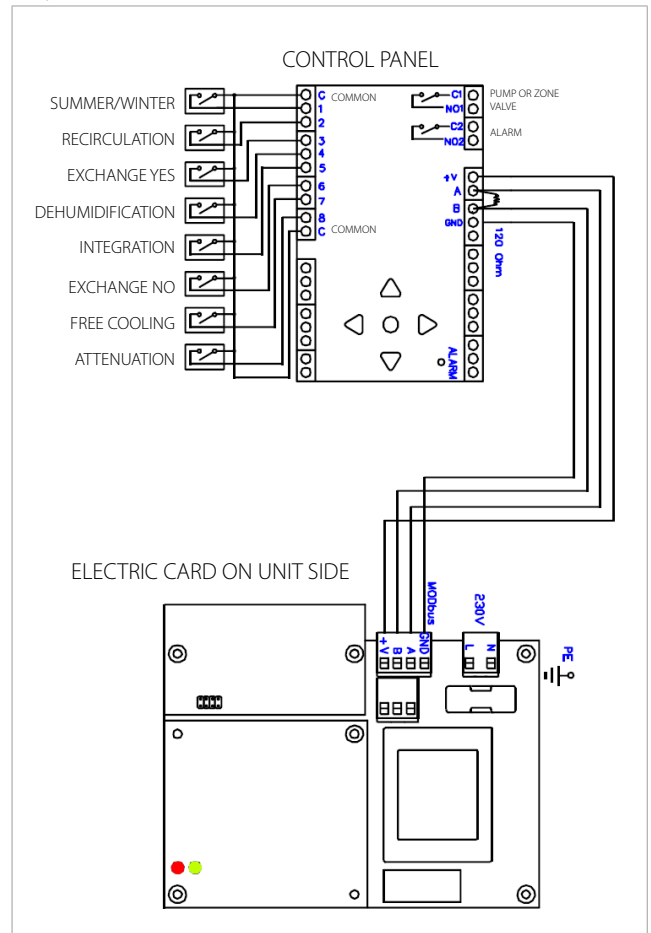

**Dimensions**

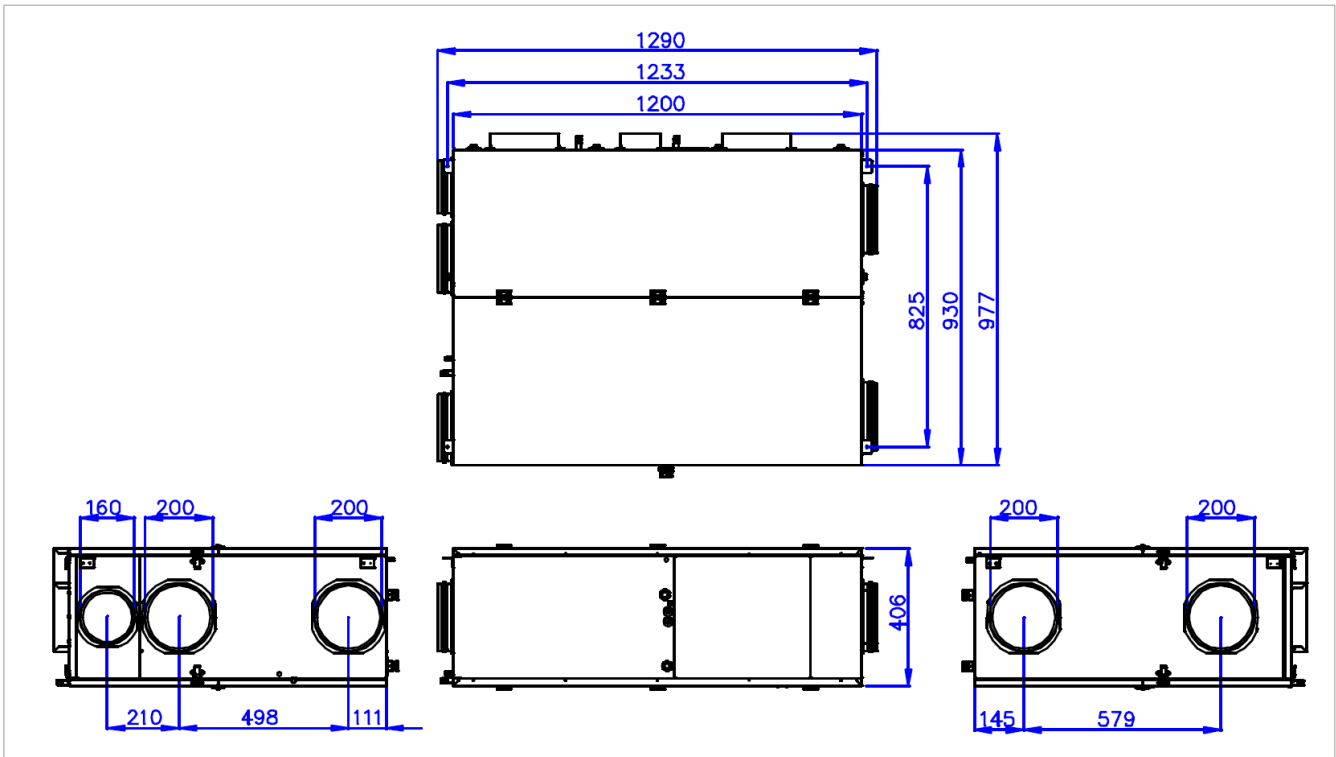

Fig. 4 - Dimensions in mm

**Product specifications**

**KDV RAY500**

Duct-type monoblock air treatment unit for ventilation, dehumidification and sensitive power integration for ceiling installation; to be combined with cooling radiant systems, complete of high-efficiency counterflow heat recuperator, removable filtering section in synthetic material class G3 (EN779:2002), 2"brushless" centrifugal fans with motor coupled directly, n. 5 motorized dampers, refrigerating circuit with R134a refrigerating gas, hydraulic circuit, treatment coils with copper pipe and aluminum fins, 5 delivery outputs, recirculation, external outlet, Ø200 mm ejection and Ø 160 mm extraction. Total flow rate 160÷500 m<sup>3</sup>/h. External air flow rate 160÷300 m<sup>3</sup>/h. Dehumidification capacity 31,2 l/24h (referred to internal rooms). Water connections 2x1/2"F. Power 230 V.

**Additional information**

For more information, go to [www.giacomini.com](http://www.giacomini.com) or contact our technical assistance service: ☎ +39 0322 923372 📠 +39 0322 923255 ✉ [consulenza.prodotti@giacomini.com](mailto:consulenza.prodotti@giacomini.com)

This document provides only general indications. Giacomini S.p.A. may change at any time, without notice and for technical or commercial reasons, the items included herewith.

The information included in this technical sheet do not exempt the user from strictly complying with the rules and good practice standards in force.

Giacomini S.p.A. Via per Alzo, 39 - 28017 San Maurizio d'Opaglio (NO) Italy