

Description

The metering modules of the GE555 series (depth 110 mm) are used to measure heat energy consumption (heating and conditioning) in centralised systems with the centralised production of sanitary hot water as well.

If sanitary hot water needs to be produced in the home, service satellites (GE556 series) are used.

In the GE555 user modules, distribution network balancing is essential in order to guarantee the same conditions for all users and ensure the meters work close to the nominal project flow rates.

The modules can house units for measuring the consumption of sanitary water and/or service water (not suitable for drinking).

The series of standard cabinets includes the following versions:

- **GE555Y461**: cabinet 500x500x110-160 mm with 3/4" connections and balancing of the by-pass only. 2 sanitary units can be housed.
- **GE555Y462, GE555Y463**: cabinet 600x600x110-160 mm with 3/4" and 1" connections, with static and by-pass balancing. 3 sanitary units can be housed (e.g. hot, cold and service water).
- **GE555Y468, GE555Y469**: cabinet 600x600x110-160 mm with 3/4" and 1" connections, with dynamic and by-pass balancing. 3 sanitary units can be housed (e.g. hot, cold and service water).

Main characteristics

- 3/4" or 1" connections.
- Cabinet depth 110 mm.
- Flush-mounting cabinet with padlock and guides for fixing metering units. Adjustable frame depth (110-160 mm) and hot-painted door (white RAL9010).
- Horizontal or vertical assembly (not upside down).
- The shut-off valves can be sealed with a meter and temperature probes.
- 3-way zone valve, motorizable.
- Plastic spacer for installation of energy meter.
- Electric box IP55, with electric terminal board.
- Rails for installation of sanitary water units, GE550 or GE550-1 series.

Technical data

- Max. working temperature: 110 °C (90 °C with plastic spacer)
- Max. working pressure: 16 bar (10 bar with plastic spacer)

Versions and product codes

Product code	Type of balancing	Connect.	Nr. of guides for sanitary units	Dimensions [mm]
GE555Y461	by-pass	3/4"	2	500x500x110÷160
GE555Y462	static + by-pass	3/4"	3	600x600x110÷160
GE555Y463	static + by-pass	1"	3	600x600x110÷160
GE555Y468	dynamic+by-pass	3/4"	3	600x600x110÷160
GE555Y469	dynamic+by-pass	1"	3	600x600x110÷160

Components

Legend	
1	Metal cabinet
2	Actuator for zone valve (optional)
3	3-way zone valve
4	Filter
5	By-pass adjustment lockshield valve
6	Housing for energy meter delivery temperature probe
7a	Static balancing valve R206B-1 (for GE555Y462, GE555Y463 modules)
7b	Dynamic balancing valve R206A (for GE555Y468, GE555Y469 modules)
8	Cabinet with electric terminal board
9	Thermal energy meter (optional)
10	Units for hot and sanitary cold water (optional)
11	Unit for service water (optional)

Optional

- Thermal energy meter, GE552 series
- Sanitary water units (hot, cold, service water), GE550 series
- Sanitary water units with thermostat mixer, GE550-1 series
- Actuator for zone valve, K270 series
- Insulation, GE551-4 series
- Components for M-Bus data centralization GE552-4 series, or Wireless M-Bus GE552-W series.

Operation

Legend			
	Shut-off valve		Spacer for thermal energy meter
	Filter		Housing for energy meter delivery temperature probe
	3-way zone valve, motorizable		Adjustment lockshield valve for the third way of the zone valve
	Differential by-pass valve		Balancing valve static / dynamic
A	Centralized boiler room	B	Heating or conditioning user

The difference between the GE555 modules is the type of balancing. As an example, we will consider dynamic balancing (codes GE555Y468, GE555Y469).

The fluid (heating or conditioning) from the centralised boiler room (A) enters the upper delivery unit. If the zone valve is open, the fluid reaches the user (B). If the zone valve is closed, the flow returns towards (A) via the third way of the zone valve. An adjustment lockshield valve allows the balancing of the by-pass. If you want the module to work as a 2-way zone valve, close this lockshield valve completely.

The zone valve can be commanded by an actuator (to be ordered separately) that is activated by a thermostat command.

The thermal energy meter (to be ordered separately) should be installed in place of the plastic spacer; the energy meter delivery probe is inserted in the housing of the shut-off valve on the delivery unit. The meter return temperature probe is integrated in the energy meter body.

The energy meter measures the flow rate and the temperature difference between the heating fluid delivery and return: it then uses these measurements to determine the heat energy consumption. Thanks to its double register, the energy meter can measure consumption for heating and/or conditioning in separate registers.

The static balancing valve (envisaged in GE555Y462, GE555Y463 modules) is used for the static adjustment of the flow rate to the apartment (B): using the energy meter, you can view the instantaneous flow rate to verify that the balancing is correct.

Hydraulic characteristics

<p>Zone valve by-pass lockshield valve 5 Use an 8 mm Allen spanner</p>	<p>Static balancing valve 7a Graduated scale on the handle</p>	<p>Dynamic balancing valve 7b Calibrate the cartridge with an 8 mm spanner</p>

Dynamic balancing characteristics 7b

3/4" balancing valve - Δp: 30-400 kPa (GE555Y468)					
Setting	l / sec	l / h	Setting	l / sec	l / h
1.0	0.113	406	3.1	0.238	857
1.1	0.119	427	3.2	0.244	879
1.2	0.125	449	3.3	0.250	900
1.3	0.131	470	3.4	0.256	922
1.4	0.137	492	3.5	0.262	943
1.5	0.143	513	3.6	0.268	965
1.6	0.149	535	3.7	0.274	987
1.7	0.155	556	3.8	0.280	1010
1.8	0.161	578	3.9	0.286	1030
1.9	0.167	599	4.0	0.292	1050
2.0	0.172	621	4.1	0.298	1070
2.1	0.178	642	4.2	0.304	1090
2.2	0.184	664	4.3	0.310	1120
2.3	0.190	685	4.4	0.316	1140
2.4	0.196	707	4.5	0.322	1160
2.5	0.202	728	4.6	0.328	1180
2.6	0.208	750	4.7	0.334	1200
2.7	0.214	771	4.8	0.340	1220
2.8	0.220	793	4.9	0.346	1240
2.9	0.226	814	5.0	0.352	1270
3.0	0.232	836			

1" balancing valve - Δp: 17-400 kPa (GE555Y469)					
Setting	l / sec	l / h	Setting	l / sec	l / h
1.0	0.149	535	3.1	1.17	4220
1.1	0.220	793	3.2	1.20	4320
1.2	0.289	1040	3.3	1.23	4420
1.3	0.355	1280	3.4	1.26	4520
1.4	0.418	1510	3.5	1.28	4620
1.5	0.479	1730	3.6	1.31	4710
1.6	0.538	1940	3.7	1.33	4800
1.7	0.594	2140	3.8	1.36	4890
1.8	0.647	2330	3.9	1.38	4970
1.9	0.699	2520	4.0	1.40	5050
2.0	0.748	2690	4.1	1.43	5130
2.1	0.795	2860	4.2	1.45	5210
2.2	0.841	3030	4.3	1.47	5290
2.3	0.884	3180	4.4	1.49	5370
2.4	0.925	3330	4.5	1.51	5440
2.5	0.965	3470	4.6	1.53	5520
2.6	1.00	3610	4.7	1.55	5600
2.7	1.04	3740	4.8	1.58	5670
2.8	1.07	3870	4.9	1.60	5750
2.9	1.11	3990	5.0	1.62	5830
3.0	1.14	4100			

GE555Y461

Direct delivery and return (zone valve open)

Regulation

Kv	4,88
----	------

Passage via by-pass (zone valve closed)

No. of by-pass turns 5	1	1,5	2	2,5	3	4	5	F.O.
Kv	0,5	0,75	1,1	1,5	2	2,4	2,5	2,75

GE555Y462

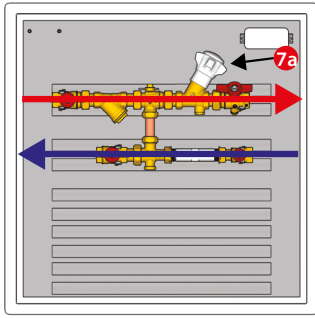

Direct delivery and return (zone valve open)

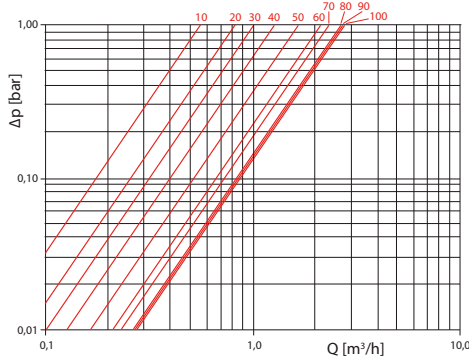

Balancing valve regulation 7a	10	20	30	40	50	60	70	80	90	100
Kv	0,55	0,80	1,00	1,20	1,60	2,15	2,40	2,65	2,7	2,75

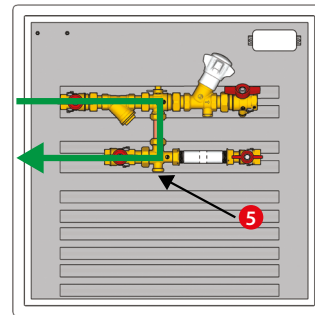

Passage via by-pass (zone valve closed)

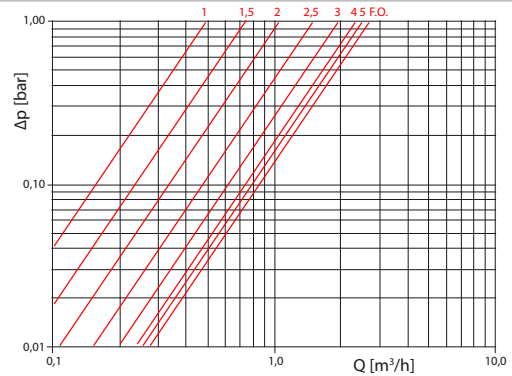

No. of by-pass turns 5	1	1,5	2	2,5	3	4	5	F.O.
Kv	0,5	0,75	1,1	1,5	2	2,4	2,5	2,75

GE555Y463

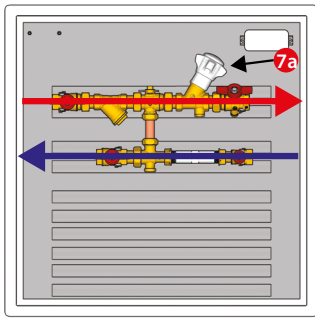

Direct delivery and return (zone valve open)

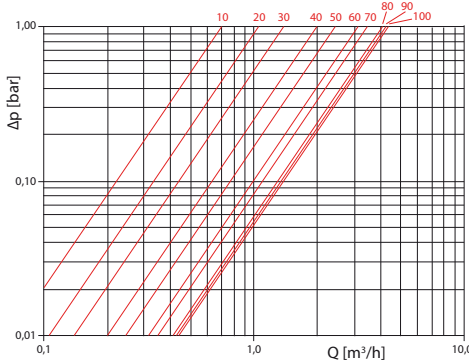

Balancing valve regulation 7a	10	20	30	40	50	60	70	80	90	100
Kv	0,7	1,1	1,4	2	2,45	3,2	3,55	4,15	4,35	4,45

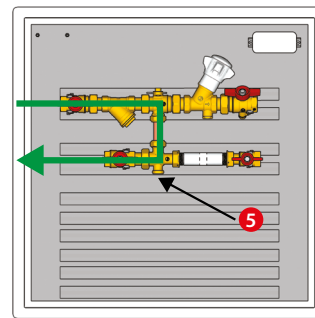

Passage via by-pass (zone valve closed)

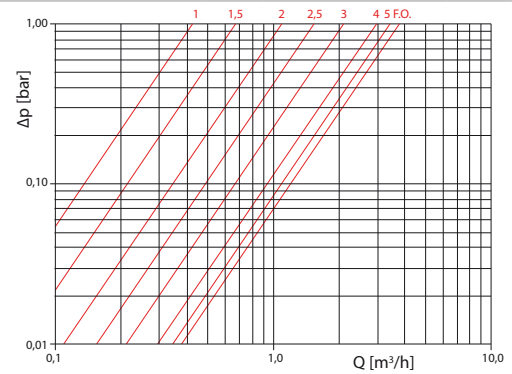

No. of by-pass turns 5	1	1,5	2	2,5	3	4	5	F.O.
Kv	0,43	0,67	1,1	1,5	2,1	3	3,5	3,8

GE555Y468

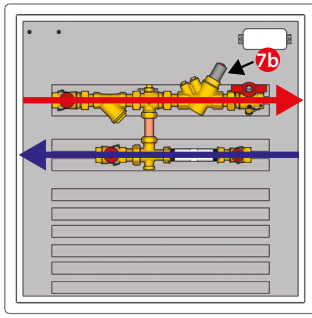

Direct delivery and return (zone valve open)

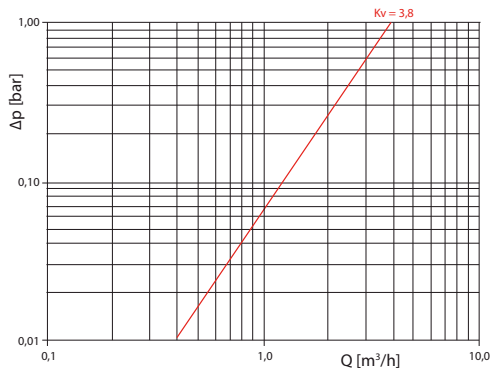

Regulation

Kv	3,8
----	-----

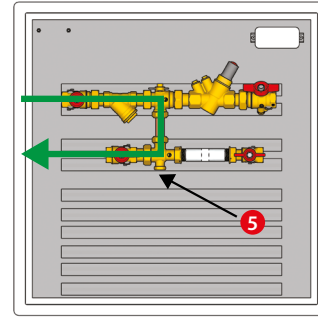

Passage via by-pass (zone valve closed)

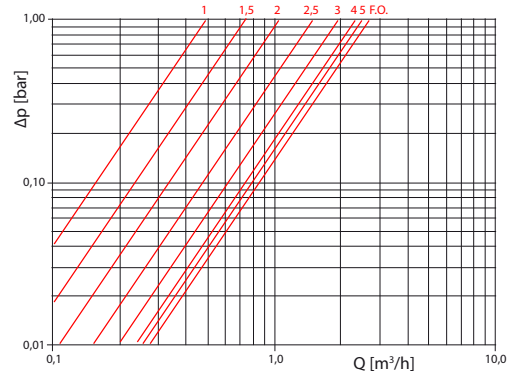

No. of by-pass turns	1	1,5	2	2,5	3	4	5	T.A.
Kv	0,5	0,75	1,1	1,5	2	2,4	2,5	2,75

GE555Y469

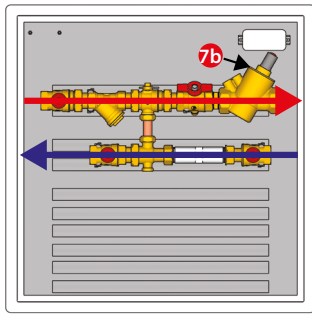

Direct delivery and return (zone valve open)

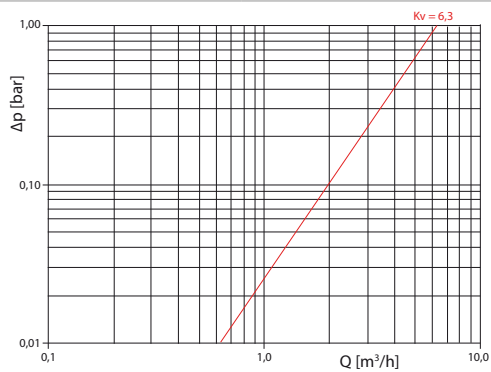

Regulation

Kv	6,3
----	-----

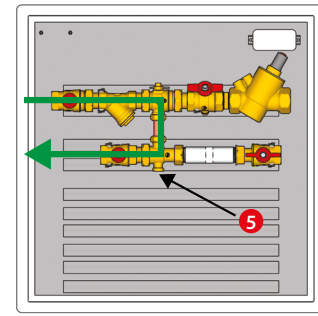

Passage via by-pass (zone valve closed)

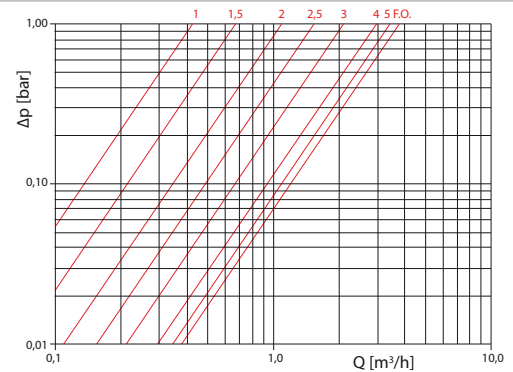

No. of by-pass turns	1	1,5	2	2,5	3	4	5	T.A.
Kv	0,43	0,67	1,1	1,5	2,1	3	3,5	3,8

Electrical connections

At the top right of the cabinet there is an IP55 electric cabinet. This contains the terminals for connecting the internal devices (K270 actuator for the zone valve, thermal energy meter and water meters) and for data centralisation via M-Bus.



Warning.
Ensure that the power supply is suspended while the connections are being carried out.

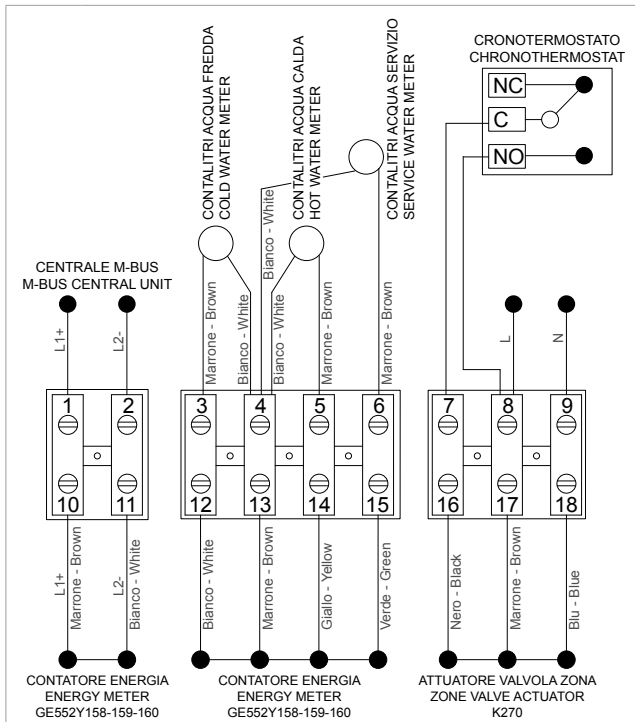

Terminal	Function
1	Cable transmitting M-Bus data to the data concentrator: connection of wire L1+. Cable Ø 0,8 mm, twisted, 2-wire, non-shielded, with a maximum line capacity of 150 pF/m (16 o 18 AWG)
2	Cable transmitting M-Bus data to the data concentrator: connection of wire L2-. Cable Ø 0,8 mm, twisted, 2-wire, non-shielded, with a maximum line capacity of 150 pF/m (16 o 18 AWG)
3	Connection for M-Bus centralization of water meters
4	Connection for M-Bus centralization of water meters
5	Connection for M-Bus centralization of water meters
6	Connection for M-Bus centralization of water meters
7	Connection to the chronothermostat, to the common C terminal of the internal contact (cable section 0,5 mm ²)
8	In parallel: connection to the chronothermostat, to the normally open NO terminal of the internal contact (cable section 0,5 mm ²)
9	Connection of power supply 24 V~ or 230 V~ (cable section 0,5 mm ²)
10	Connection of L1+ brown wire of thermal energy meter
11	Connection of L2- white wire of thermal energy meter
12	Connection for M-Bus centralization of water meters
13	Connection for M-Bus centralization of water meters
14	Connection for M-Bus centralization of water meters
15	Connection for M-Bus centralization of water meters
16	Connection K270 zone valve actuator, black wire
17	Connection K270 zone valve actuator, brown wire
18	Connection K270 zone valve actuator, blue wire



Nota.
The showed electric scheme is about the connections of GE552Y158, GE552Y159, GE552Y160 thermal energy meters. In the case of installation of other energy meters refer to the instructions of the meters themselves.

Installation



Warning.
Respect the regulations regarding the use (installation, fixing, etc.), operation, recalibration and replacement of the meters.
Refer also to the assembly instructions provided with the meter.

1) Connecting the module to the pipes of the heating and/or conditioning system.

To connect the module units to the system (heating and/or conditioning) pipes, you can disconnect the shut-off valves as they are connected by means of detachable nuts. Once the free valve connections have been firmly fixed to the system pipes, reconnect the valves (interposing the gaskets) then tighten the nuts.

2) Washing the system

The Standards (UNI EN 1432) indicate that the system must be washed before installing the energy meters. At the end of the washing, clean well the filter.

3) Installing the thermal energy meter

When the system has been washed, you can replace the plastic spacer with the thermal energy meter (Centre distance 110 mm for 3/4" modules GE555Y461, GE555Y462, GE555Y468 - Centre distance 130 mm for 1" modules GE555Y463, GE555Y469).

The module is provided with a mounting kit to be able to separately install the hydraulic part and the display of the energy meters.



Avvertenza.
For the thermal energy meter installation please refer to the instruction provided with the meter.

4) Testing the system

After making the installations, test the pressurised system according to the requirements of regional/national standards.

Dimensions

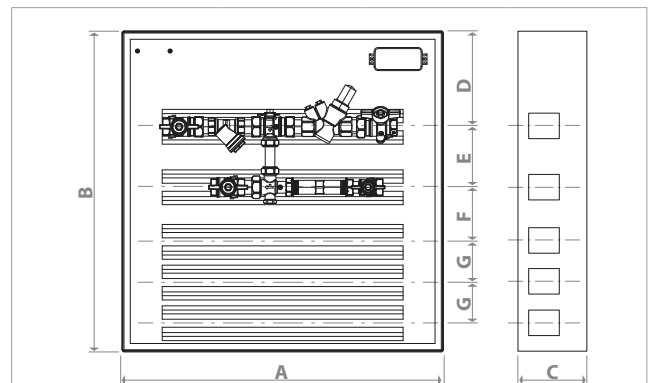

Product code	A [mm]	B [mm]	C [mm]	D [mm]	E [mm]	F [mm]	G [mm]
GE555Y461	500	500	110÷160	174	113	102	76
GE555Y462	600	600	110÷160	174	113	102	76
GE555Y463	600	600	110÷160	174	113	102	76
GE555Y468	600	600	110÷160	174	113	102	76
GE555Y469	600	600	110÷160	174	113	102	76

Reference Standards

- UNI EN 1434
- EN 60751
- EN 61107



Product specifications

GE555Y461

User module for centralized heating and conditioning systems. Connections 3/4". Shut-off ball valves on delivery and return. Filter with basket. Motorized 3-way zone valve with lockshield valve for by-pass balancing. Suitable for assembly of energy meter thanks to plastic spacer on the return line (centre distance 110 mm). Bracket for fixing the energy meter display unit. Housing for delivery temperature probe built into the shut-off ball valve. IP55 cabinet with terminal board for electric connections. Two guides for assembling the sanitary water metering units. Painted sheet metal cabinet (RAL9010) with lockable door and adjustable frame depth. Dimensions 500x500x110÷160 mm (LxHxD). Max. working temperature 110 °C (90 °C with plastic spacer). Max. working pressure 16 bar (10 bar with plastic spacer). The module can be completed with thermal energy meters GE552 series. Units GE550 or GE550-1 series for metering sanitary water. Actuator K270 for 3-way zone valve. Insulation GE551-4 series. Components for centralisation and remote command of consumption data via M-Bus, GE552-4 series or via Wireless M-Bus, GE552-W series.

GE555Y462

User module for centralized heating and conditioning systems. Connections 3/4". Shut-off ball valves on delivery and return. Filter with basket. Motorized 3-way zone valve with lockshield valve for by-pass balancing. Static balancing valve. Suitable for assembly of energy meter thanks to plastic spacer on the return line (centre distance 110 mm). Bracket for fixing the energy meter display unit. Housing for delivery temperature probe built into the shut-off ball valve. IP55 cabinet with terminal board for electric connections. Three guides for assembling the sanitary water metering units. Painted sheet metal cabinet (RAL9010) with lockable door and adjustable frame depth. Dimensions 600x600x110÷160 mm (LxHxD). Max. working temperature 110 °C (90 °C with plastic spacer). Max. working pressure 16 bar (10 bar with plastic spacer). The module can be completed with thermal energy meters GE552 series. Units GE550 or GE550-1 series for metering sanitary and/or service water. Actuator K270 for 3-way zone valve. Insulation GE551-4 series. Components for centralisation and remote command of consumption data via M-Bus, GE552-4 series or via Wireless M-Bus, GE552-W series.

GE555Y463

User module for centralized heating and conditioning systems. Connections 1". Shut-off ball valves on delivery and return. Filter with basket. Motorized 3-way zone valve with lockshield valve for by-pass balancing. Static balancing valve. Suitable for assembly of energy meter thanks to plastic spacer on the return line (centre distance 130 mm). Bracket for fixing the energy meter display unit. Housing for delivery temperature probe built into the shut-off ball valve. IP55 cabinet with terminal board for electric connections. Three guides for assembling the sanitary water metering units. Painted sheet metal cabinet (RAL9010) with lockable door and adjustable frame depth. Dimensions 600x600x110÷160 mm (LxHxD). Max. working temperature 110 °C (90 °C with plastic spacer). Max. working pressure 16 bar (10 bar with plastic spacer). The module can be completed with thermal energy meters GE552 series. Units GE550 or GE550-1 series for metering sanitary and/or service water. Actuator K270 for 3-way zone valve. Insulation GE551-4 series. Components for centralisation and remote command of consumption data via M-Bus, GE552-4 series or via Wireless M-Bus, GE552-W series.

GE555Y468

User module for centralized heating and conditioning systems. Connections 3/4". Shut-off ball valves on delivery and return. Filter with basket. Motorized 3-way zone valve with lockshield valve for by-pass balancing. Dynamic balancing valve. Suitable for assembly of energy meter thanks to plastic spacer on the return line (centre distance 110 mm). Bracket for fixing the energy meter display unit. Housing for delivery temperature probe built into the shut-off ball valve. IP55 cabinet with terminal board for electric connections. Three guides for assembling the sanitary water metering units. Painted sheet metal cabinet (RAL9010) with lockable door and adjustable frame depth. Dimensions 600x600x110÷160 mm (LxHxD). Max. working temperature 110 °C (90 °C with plastic spacer). Max. working pressure 16 bar (10 bar with plastic spacer). The module can be completed with thermal energy meters GE552 series. Units GE550 or GE550-1 series for metering sanitary and/or service water. Actuator K270 for 3-way zone valve. Insulation GE551-4 series. Components for centralisation and remote command of consumption data via M-Bus, GE552-4 series or via Wireless M-Bus, GE552-W series.

GE555Y469

User module for centralized heating and conditioning systems. Connections 3/4". Shut-off ball valves on delivery and return. Filter with basket. Motorized 3-way zone valve with lockshield valve for by-pass balancing. Dynamic balancing valve. Suitable for assembly of energy meter thanks to plastic spacer on the return line (centre distance 130 mm). Bracket for fixing the energy meter display unit. Housing for delivery temperature probe built into the shut-off ball valve. IP55 cabinet with terminal board for electric connections. Three guides for assembling the sanitary water metering units. Painted sheet metal cabinet (RAL9010) with lockable door and adjustable frame depth. Dimensions 600x600x110÷160 mm (LxHxD). Max. working temperature 110 °C (90 °C with plastic spacer). Max. working pressure 16 bar (10 bar with plastic spacer). The module can be completed with thermal energy meters GE552 series. Units GE550 or GE550-1 series for metering sanitary and/or service water. Actuator K270 for 3-way zone valve. Insulation GE551-4 series. Components for centralisation and remote command of consumption data via M-Bus, GE552-4 series or via Wireless M-Bus, GE552-W series.

Additional information

For additional information please check the website www.giacomini.com or contact the technical service: ☎ +39 0322 923372 📠 +39 0322 923255 ✉ consulenza.prodotti@giacomini.com
 This pamphlet is merely for information purposes. Giacomini S.p.A. retains the right to make modifications for technical or commercial reasons, without prior notice, to the items described in this pamphlet. The information described in this technical pamphlet does not exempt the user from following carefully the existing regulations and norms on good workmanship.
 Giacomini S.p.A. Via per Alzo, 39 - 28017 San Maurizio d'Opaglio (NO) Italy