

**Description**

GE555-3 user modules represent the heat metering solution for the systems of apartment blocks having centralized production of the heating water, sanitary hot water and zone distribution.

They also control the heating and cooling system of the single house, thanks to the presence of a zone valve motorizable to be subjugated to the thermostat or chronothermostat of the house.

In addition to the thermal energy, GE555-3 modules can also detect the domestic cold and hot water consumptions through the installation of the appropriate GE550 or GE550-1 unit outputs.

**Use**

The user modules with integrated hydraulic separator permit the complete hydraulic separation of the primary and secondary flows.

For this reason they are particularly suitable to be used where different house units have terminals, that require different supply temperatures and temperature differences between delivery and return.

They also represent the ideal solution when, in the same house unit, there is a mixed system (for example radiant panel floor or heating systems used either for the heating or for the cooling of the rooms).

Depending on the versions, the modules on the secondary can have at their disposal mixed zones, zones with direct connection or a combination of the two.

**Main features**

- 3/4" connections.
- Insulated hydraulic separator for the hydraulic separation between the primary and the secondary circuits, equipped with drain cock, manual air vent valve and manometer.
- On the secondary circuit possibility of two zones, for uses with mixed water and/or for uses with not mixed water.
- Zone valve motorizable.
- Cabinet with terminal board for electrical connections.
- Housing for delivery temperature probe.
- Connection and fixing fittings.
- Predisposition for housing in template equipped with guides for the connection of domestic water units and/or service water and shut-off valves
- Dimensions (with template) 700x750x110÷140 mm (LxHxD).
- Predisposition for the installation of energy meter through a plastic spacer.
- Self-modulating circulator/s in compliance with 2009/125/CE ErP directive.

**Technical data**

- Maximum working temperature: 90 °C
- Maximum working pressure: 10 bar
- Electrical supply: 230 V
- Protection degree: IPx4D (circulators)

**Electrical power**

Product code	Power and electrical current of the circulators	N° of circulator (self-modulating, complying with ErP directive)
GE555Y508 GE555Y516 GE555Y527 GE555Y538	3÷45 W (0,03÷0,44 A)	1 circulator
GE555Y526 GE555Y536	6÷90 W (0,06÷0,88 A)	2 circulators
<b>Optional- maximum powers</b>		
Actuator K270 (24 V / 230 V) = 5,5 W		
K281X012 = 2,5 W		
K282X022 = 5 W		

**Versions and product codes**

Product code	Number and type of the secondary zones	N° of circulator (self-modulating, complying with ErP directive)
GE555Y508	1 mixed zone	1
GE555Y516	1 direct zone	1
GE555Y526	2 direct zones	2
GE555Y527	2 direct zones	1
GE555Y536	1 mixed zone and 1 direct zone	2
GE555Y538	1 mixed zone and 1 direct zone	1



**Components**

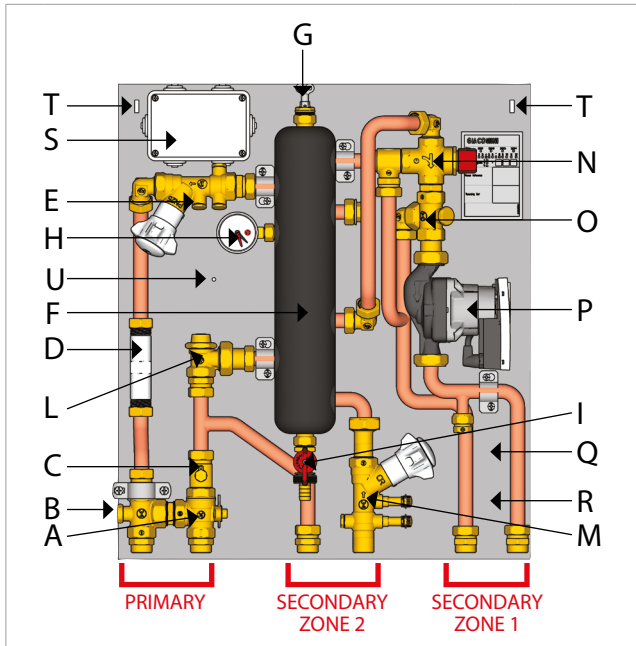

Legend

A	Zone valve motorizable	PRIMARY
B	By-pass lockshield	
C	Housing for delivery temperature probe	
D	Plastic spacer for energy meter	
E	Static balancing valve	
F	Insulated hydraulic separator	HYDRAULIC SEPARATOR
G	Air vent valve	
H	Manometer	SECONDARY ZONE 2
I	Drain cock	
L	Lockshield	
M	Static balancing valve	SECONDARY ZONE 1
N	Mixing valve	
O	By-pass lockshield for mixed zone	
P	Self-modulating circulator	
Q	Housing for delivery temperature probe	OTHER COMPONENTS
R	Housing for safety thermostat probe (optional)	
S	Cabinet with electrical terminals	
T	Holes to fix the module to the template	
U	Fixing hole of the energy meter display	

**Optional**

A series of optional accessories shall be separately ordered to make the modules work correctly. They are listed here below.

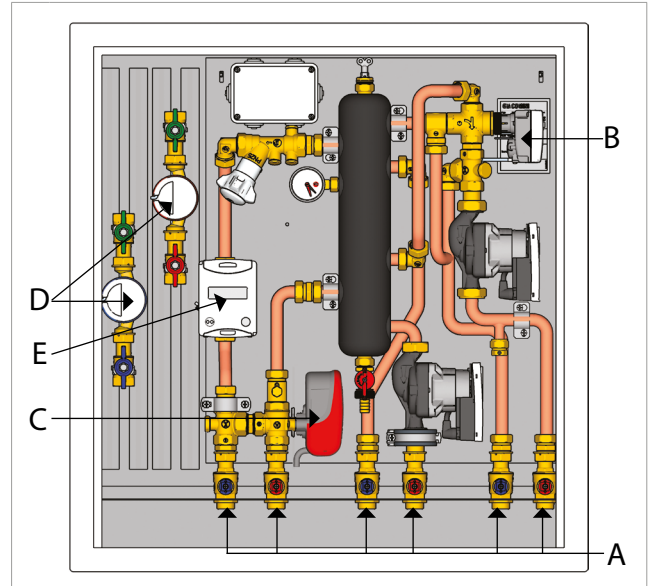

Legend

A	Template that can be closed with a padlock, RAL 9010 hot-painted. Prearranged with shut-off valve, dimensions 700x750x110 mm (LxHxD). GE551Y070 (version for a single secondary zone) GE551Y071 (version for two secondary zones)
B	Actuator for mixing valve: K281X012, K282X022
C	Actuator for zone valve. K270Y101 (230 V) K270Y102 (24 V)
D	Unit outputs for sanitary water, GE550 series As an alternative, the preassembly group with thermostatic mixer, GE550-1 series can be mounted.
E	Thermal energy meter, GE552 series
<b>OTHER ACCESSORIES:</b>	
<ul style="list-style-type: none"> <li>• Safety thermostat K373Y013 in case of secondary with mixed zone</li> <li>• Insulation, GE551Y174</li> <li>• Components for KLIMABus thermoregulation</li> <li>• Components for M-Bus centralization GE552-4, or wireless M-Bus GE552-W</li> </ul>	



**Note.**

GE551Y174 insulation has to be necessarily ordered with the use module, in order to insert during the assembling the back semi-shell between the frame and the components.

Operation

<p>Scheme GE555Y516 GE555Y526</p>	<p>Scheme GE555Y508 GE555Y536</p>																																										
<p>Scheme GE555Y527</p>	<p>Scheme GE555Y538</p>																																										
<p>Legenda connessioni</p>																																											
<table border="1"> <tr> <td>PM</td> <td>Primary delivery</td> <td>A</td> <td>Zone valve, motorizable</td> <td>I</td> <td>Drain cock</td> </tr> <tr> <td>PR</td> <td>Primary return</td> <td>B</td> <td>By-pass lockshield</td> <td>L</td> <td>Lockshield</td> </tr> <tr> <td>Z1M</td> <td>Secondary delivery – zone 1</td> <td>C</td> <td>Housing for delivery temperature sensor of the energy meter</td> <td>M</td> <td>Static balancing valve</td> </tr> <tr> <td>Z1R</td> <td>Secondary return – zone 1</td> <td>D</td> <td>Plastic spacer for energy meter</td> <td>N</td> <td>Mixing valve</td> </tr> <tr> <td>Z2M</td> <td>Secondary delivery – zone 2</td> <td>E</td> <td>Static balancing valve</td> <td>O</td> <td>By-pass lockshield of mixed zone</td> </tr> <tr> <td>Z2R</td> <td>Secondary return – zone 2</td> <td>G</td> <td>Air vent valve</td> <td>P</td> <td>Self-modulating circulator</td> </tr> <tr> <td></td> <td></td> <td>V</td> <td></td> <td>V</td> <td></td> </tr> </table>		PM	Primary delivery	A	Zone valve, motorizable	I	Drain cock	PR	Primary return	B	By-pass lockshield	L	Lockshield	Z1M	Secondary delivery – zone 1	C	Housing for delivery temperature sensor of the energy meter	M	Static balancing valve	Z1R	Secondary return – zone 1	D	Plastic spacer for energy meter	N	Mixing valve	Z2M	Secondary delivery – zone 2	E	Static balancing valve	O	By-pass lockshield of mixed zone	Z2R	Secondary return – zone 2	G	Air vent valve	P	Self-modulating circulator			V		V	
PM	Primary delivery	A	Zone valve, motorizable	I	Drain cock																																						
PR	Primary return	B	By-pass lockshield	L	Lockshield																																						
Z1M	Secondary delivery – zone 1	C	Housing for delivery temperature sensor of the energy meter	M	Static balancing valve																																						
Z1R	Secondary return – zone 1	D	Plastic spacer for energy meter	N	Mixing valve																																						
Z2M	Secondary delivery – zone 2	E	Static balancing valve	O	By-pass lockshield of mixed zone																																						
Z2R	Secondary return – zone 2	G	Air vent valve	P	Self-modulating circulator																																						
		V		V																																							

Operation of the primary circuit

- The heating fluid coming from the centralized boiler room, enters in PM connection and meets the zone valve (A) on which it is possible mounting an actuator (K270 series) to be activated by the thermostat control.
- If the zone valve (A) is opened, the fluid goes in the hydraulic separator and comes back through the balancing valve (E) going out from PR connection.
- The balancing of the primary can be made through the balancing valve (E).
- The thermal energy meter, that can be installed by replacing the plastic spacer (D), measures the capacity and the temperature difference of the heating fluid between delivery and return, through the temperature probes: with these measures it determines the thermal energy consumption (heating and/or cooling)
- The hydraulic separator permits the dynamic separation of the primary and secondary circuits.

Operation of the primary circuit, in by-pass

- If the zone valve (A) is closed, the operation is in by-pass with passage through the by-pass of the zone valve and lockshield (B).

Operation of the secondary circuit

- On the secondary circuit different configurations are possible; one or two zones can be supplied.
- For zone 1, the presence of a circulator (P) is always expected, this zone can have direct connection or mixed one - in this case the mixing valve (N) and the by-pass (O) are present.
  - For zone 2 (not present for all the product codes), the direct connection is always expected (without mixing valve). As an alternative, in presence of the (V) circulator, the configuration with the lockshield (L) and the balancing (M) can be chosen: in this case the hydraulic head is supplied by the boiler room circulator.



Hydraulic characteristics

Primary circuit

► Static balancing valve R206B (ref. E - "components")

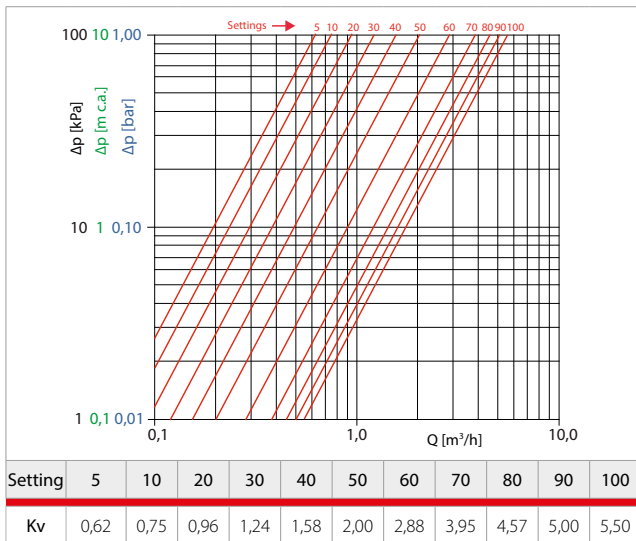

► Lockshield of the by-pass of the 3-way zone valve

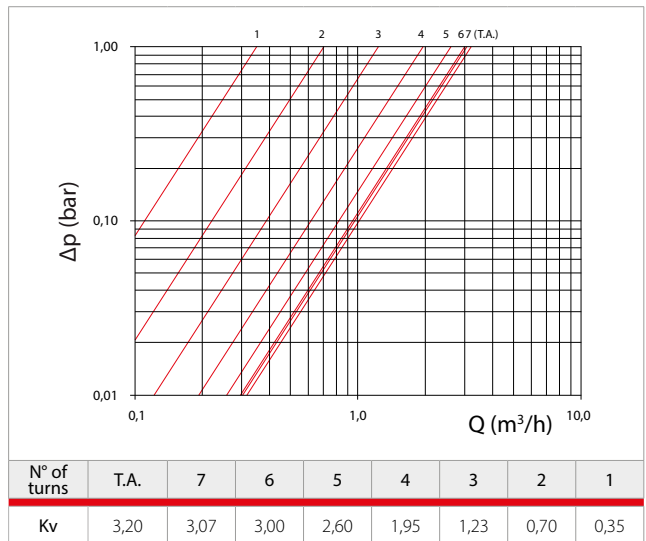

Secondary circuit

► Zone 1 (mixed zone)

- Mixing valve (ref. N - "components") – nominal Kv: 2,17
- Lockshield of the by-pass of the mixing valve (ref. O - "components"): features equal to those ones of the by-pass of the 3-way zone valve on the primary

► Zone 2 (direct zone, without circulator)

- Static balancing valve R206B (ref. M - "components"): features equal to those ones of the balancing valve on the primary
- Lockshield (ref. L - "components"): see note below



Note.

For the versions with double secondary zone and single circulator (modules GE555Y527, GE555Y538), in the area SECONDARY ZONE 2 ("components"), maximum 300 l/h and 3 m w.c. can be obtained – with a primary hydraulic head of 0,5 bar: adjust the lockshield (ref. 1 - "components") with 1 opening turn.

High-efficiency circulator 15/6 (230 V)	Circulator operating	
  		Automatic constant pressure difference (recommended).
		Automatic variable pressure difference.
		Automatic air vent routine (10 min duration): the circulator runs alternatively with high and low speeds to help air bubbles to agglomerate and to go to air vent of the installation.
	LED - errors	
		Normal running.
	Automatic operation to release the air.	
	Abnormal situation (circulator functional but stopped): 1) Undervoltage or overvoltage 2) Wrong temperature (fluid or room temperature)	
	Circulator stopped (permanent error: the circulator need a manual reset). It can be necessary to change the circulator.	
	No power supply: 1) Circulat. is not connected to power supply; check cable connection. 2) LED is damaged: check if circulator is running. 3) Electronics are damaged: change circulator.	



Electrical connections



**Warning.**  
Make sure to remove the supply voltage during the joint execution.



**Nota.**  
The showed electric scheme is about the connections of GE552Y158, GE552Y159 thermal energy meters. In the case of installation of other energy meters refer to the instructions of the meters themselves.

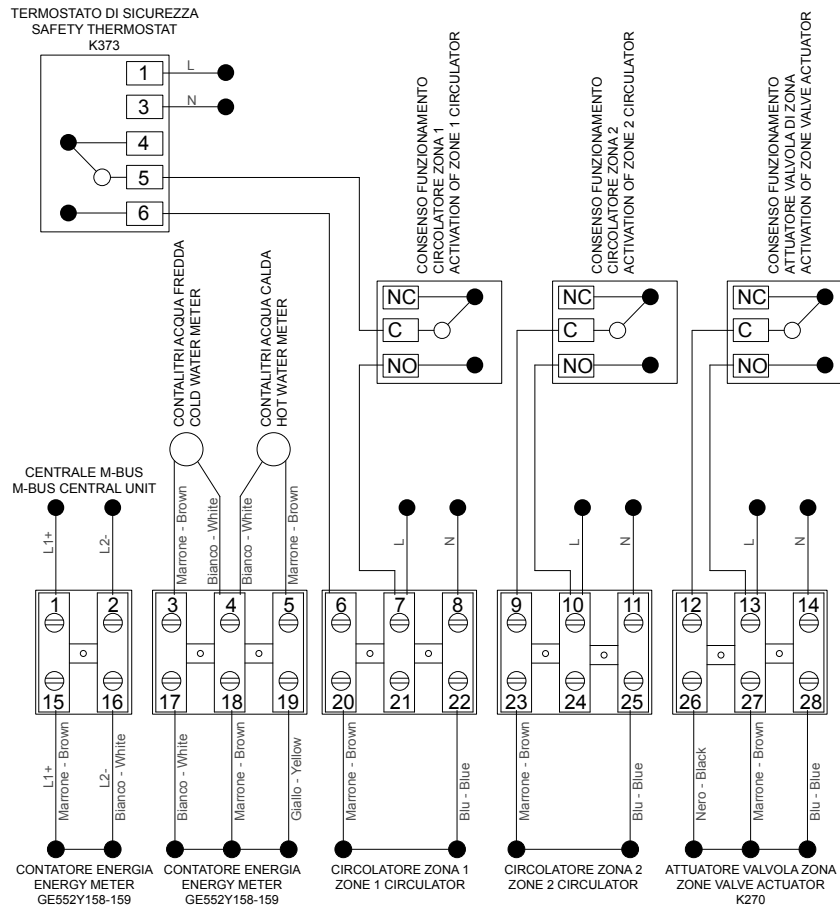

Terminal	Function
1	Cable transmitting M-Bus data to the data concentrator: connection of wire L1+. Cable Ø 0,8 mm, twisted, 2-wire, non-shielded, with a maximum line capacity of 150 pF/m (16 o 18 AWG)
2	Cable transmitting M-Bus data to the data concentrator: connection of wire L2-. Cable Ø 0,8 mm, twisted, 2-wire, non-shielded, with a maximum line capacity of 150 pF/m (16 o 18 AWG)
3	Connection for M-Bus centralization of water meters
4	Connection for M-Bus centralization of water meters
5	Connection for M-Bus centralization of water meters
6	Connection to safety thermostat K373 (optional) or to the chronothermostat, to the common C terminal of the internal contact
7	Connection of power supply 24 V~ or 230 V~ (cable section 0,5 mm <sup>2</sup> ) In parallel: connection to the chronothermostat, to the normally open NO terminal of the internal contact (cable section 0,5 mm <sup>2</sup> )
8	Connection of power supply 24 V~ or 230 V~ (cable section 0,5 mm <sup>2</sup> )
9	Connection to the chronothermostat, to the common C terminal of the internal contact (cable section 0,5 mm <sup>2</sup> )
10	Connection of power supply 24 V~ or 230 V~ (cable section 0,5 mm <sup>2</sup> ) In parallel: connection to the chronothermostat, to the normally open NO terminal of the internal contact (cable section 0,5 mm <sup>2</sup> )
11	Connection of power supply 24 V~ or 230 V~ (cable section 0,5 mm <sup>2</sup> )
12	Connection to the chronothermostat, to the common C terminal of the internal contact (cable section 0,5 mm <sup>2</sup> )
13	Connection of power supply 24 V~ or 230 V~ (cable section 0,5 mm <sup>2</sup> ) In parallel: connection to the chronothermostat, to the normally open NO terminal of the internal contact (cable section 0,5 mm <sup>2</sup> )
14	Connection of power supply 24 V~ or 230 V~ (cable section 0,5 mm <sup>2</sup> )

Terminal	Function
15	Connection of L1+ brown wire of thermal energy meter
16	Connection of L2- white wire of thermal energy meter
17	Connection for M-Bus centralization of water meters
18	Connection for M-Bus centralization of water meters
19	Connection for M-Bus centralization of water meters
20	Connection to the brown wire of zone 1 circulator
21	-
22	Connection to the blue wire of zone 1 circulator
23	Connection to the brown wire of zone 2 circulator
24	-
25	Connection to the blue wire of zone 2 circulator
26	Connection K270 zone valve actuator, black wire
27	Connection K270 zone valve actuator, brown wire
28	Connection K270 zone valve actuator, blue wire



Electrical connections if is used the KLIMAbus thermoregulation



**Warning.**  
For the real connections of the adjustment regulator, refer to the printouts that support the design (Giacomini's technical service).

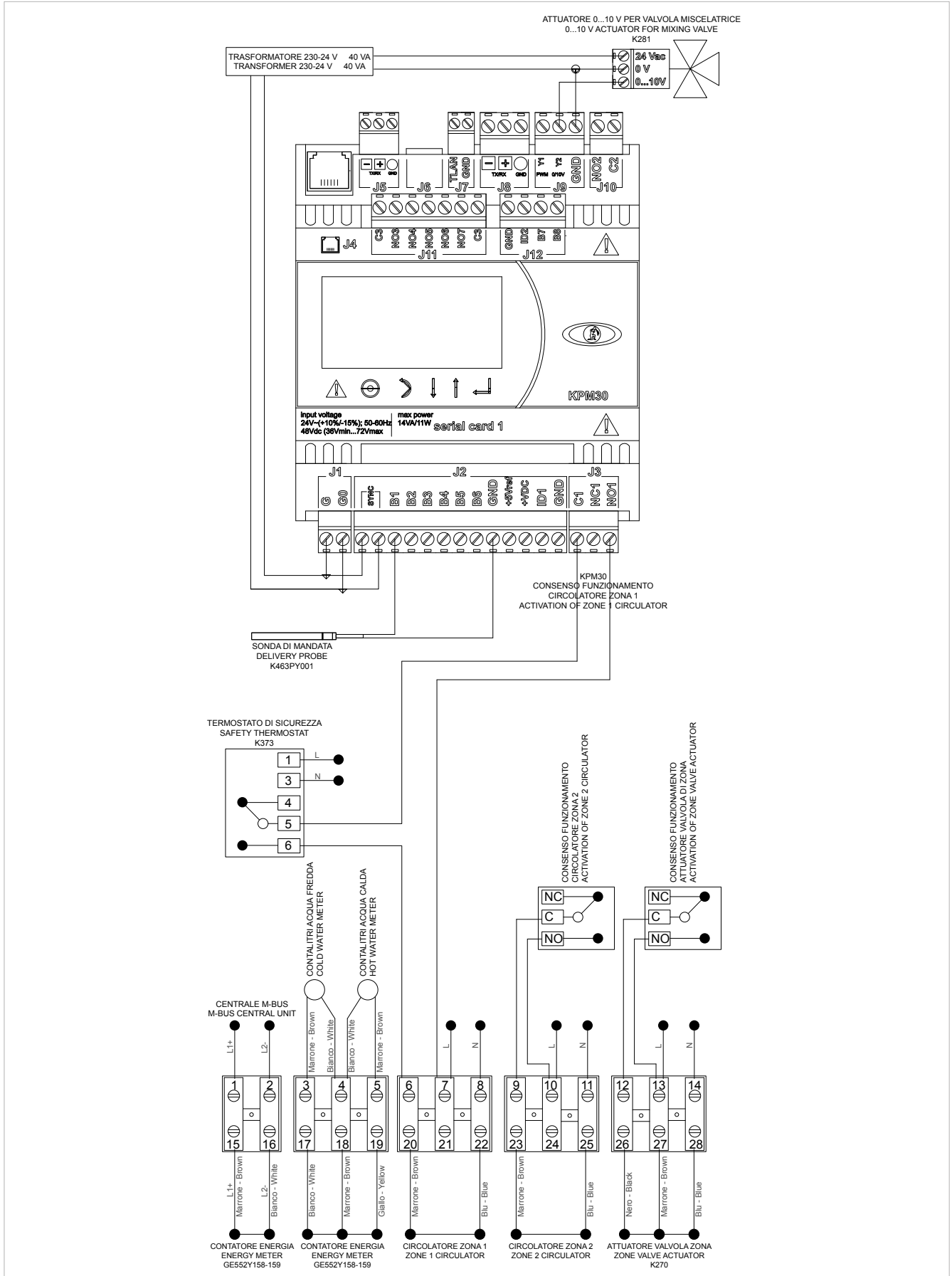

Installation



**Warning.**  
Respect the regulations regarding the use (installation, fixing, etc.), operation, recalibration and replacement of the meters.  
Refer also to the assembly instructions provided with the meter.

The module installation normally expects the use of a template for the working site, available in the following versions:

- GE551Y070 (for modules with 1 zone on the secondary, 4 shut-off valves)
- GE551Y071 (for modules with 2 zones on the secondary, 6 shut-off valves)

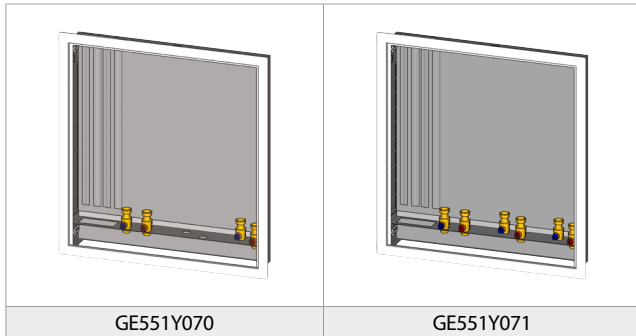

In addition to the installation of the module, the template allows the mounting of two GE550 or a GE550-1 unit outputs, for the metering of the domestic water consumptions, thanks to the proper vertical guides. The template is endowed with a frame of adjustable depth (30 mm) to compensate for the difference due to the application of the wall plaster.

1) Installation of the template

We recommend the installation of the single template on the working site. It permits to fix the domestic unit outputs through the guides and it allows making the connections to the systems through the shut-off valves.



**Warning.**  
If modules with insulation GE551Y174 are used, the frame of the template must be necessarily regulated with a depth equal to 140 mm.

2) Washing the system

The Standards (UNI EN 1432) indicate that the system must be washed before installing the energy meters. At the end of the washing, clean well the filter.

3) Installation of the template module

After the system washing, proceed with the installation of the module in the template.

- Insert the module in the template, by leaning the male fittings of the module to the valves with nuts of the template. Tighten the fittings by hands.
- Fix the module to the template through two screws, to be fixed to the female threads on the template through the two buttonholes up on the right and on the left.
- Tighten all adaptors.

4) Installing the thermal energy meter

When the system has been washed, you can replace the plastic spacer with the thermal energy meter (centre distance 110 mm). The module is provided with a mounting kit to be able to separately install the hydraulic part and the display of the energy meters.



**Warning.**  
For the thermal energy meter installation please refer to the instruction provided with the meter.

5) Testing the system

After making the installations, test the pressurised system according to the requirements of regional/national standards.

Dimensions

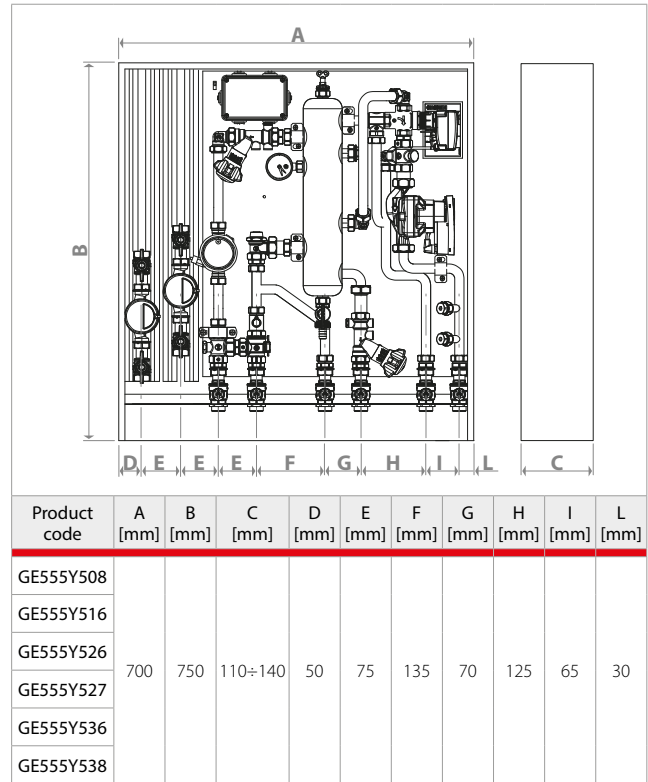

Reference Standards

- UNI EN 1434
- EN 60751
- EN 61107



**AVVERTENZE PER IL CORRETTO SMALTIMENTO DEL PRODOTTO**

Questo prodotto rientra nel campo di applicazione della Direttiva 2012/19/UE riguardante la gestione dei rifiuti di apparecchiature elettriche ed elettroniche (RAEE). L'apparecchio non deve essere eliminato con gli scarti domestici in quanto composto da diversi materiali che possono essere riciclati presso le strutture adeguate. Informarsi attraverso l'autorità comunale per quanto riguarda l'ubicazione delle piattaforme ecologiche atte a ricevere il prodotto per lo smaltimento ed il suo successivo corretto riciclaggio. Si ricorda, inoltre, che a fronte di acquisto di apparecchio equivalente, il distributore è tenuto al ritiro gratuito del prodotto da smaltire. Il prodotto non è potenzialmente pericoloso per la salute umana e l'ambiente, ma se abbandonato nell'ambiente impatta negativamente sull'ecosistema. Leggere attentamente le istruzioni prima di utilizzare l'apparecchio per la prima volta. Si raccomanda di non usare assolutamente il prodotto per un uso diverso da quello a cui è stato destinato, essendoci pericolo di shock elettrico se usato impropriamente.



Il simbolo del bidone barrato, presente sull'etichetta posta sull'apparecchio, indica la rispondenza di tale prodotto alla normativa relativa ai rifiuti di apparecchiature elettriche ed elettroniche.  
L'abbandono nell'ambiente dell'apparecchiatura o lo smaltimento abusivo della stessa sono puniti dalla legge.



**IMPORTANT INFORMATION FOR CORRECT DISPOSAL OF THE PRODUCT**

This product falls into the scope of the Directive 2012/19/EU concerning the management of Waste Electrical and Electronic Equipment (WEEE). This product shall not be disposed in to the domestic waste as it is made of different materials that have to be recycled at the appropriate facilities. Inquire through the municipal authority regarding the location of the ecological platforms to receive the product for disposal and its subsequent correct recycling. Furthermore, upon purchase of an equivalent appliance, the distributor is obliged to collect the product for disposal free of charge. The product is not potentially dangerous for human health and the environment, but if abandoned in the environment can have negative impact on the environment. Read carefully the instructions before using the product for the first time. It is recommended that you do not use the product for any purpose rather than those for which it was intended, there being a danger of electric shock if used improperly.



The crossed-out wheeled dustbin symbol, on the label on the product, indicates the compliance of this product with the regulations regarding Waste Electrical and Electronic Equipment.  
Abandonment in the environment or illegal disposal of the product is punishable by law.



**AVERTISSEMENTS POUR L'ÉLIMINATION CORRECTE DU PRODUIT**

Ce produit entre dans le champ d'application de la directive 2012/19 / UE relative à la gestion des déchets équipements électriques et électroniques (DEEE). L'appareil ne doit pas être jeté avec les ordures ménagères car il est fait de différents matériaux pouvant être recyclés dans des centres appropriés. Renseignez-vous auprès de l'autorité locale concernant l'emplacement des plates-formes écologiques appropriées pour recevoir le produit pour sa destruction et son recyclage correct ultérieur. Il convient également de rappeler que, en cas d'achat d'un appareil équivalent, le distributeur est tenu de collecter le produit à détruire. Le produit n'est potentiellement pas dangereux pour la santé humaine et l'environnement, mais s'il est abandonné dans l'environnement, il a un impact négatif sur l'écosystème. Lisez attentivement les instructions avant d'utiliser l'appareil pour la première fois. Il est interdit d'utiliser le produit pour un usage différent de celui auquel il était destiné, il y a risque de choc électrique si utilisé incorrectement.



Le symbole de la poubelle barrée sur l'étiquette de l'appareil indique sa correspondance produit à la législation relative aux déchets d'équipements électriques et électroniques.  
L'abandon dans l'environnement de l'équipement ou l'élimination illégale de l'équipement est punissable par la loi.



**WICHTIGE HINWEISE ZUR KORREKTEN ENTSORGUNG DES PRODUKTS**

Dieses Produkt fällt in den Anwendungsbereich der Richtlinie 2012/19/EU über die Entsorgung von Elektro- und Elektronik - Altgeräten (WEEE). Dieses Produkt darf nicht in den Hausmüll entsorgt werden, da es aus verschiedenen Materialien besteht, die in entsprechenden Einrichtungen recycelt werden müssen. Erkundigen sie sich bei ihrer Gemeinde nach dem Standort des nächsten Recyclinghofs bzw. der nächsten Annahmestelle, um das Produkt dem Recycling zuzuführen bzw. fachgerecht zu entsorgen. Darüber hinaus ist der Händler verpflichtet, das Produkt beim Kauf eines gleichwertigen Geräts kostenlos zu entsorgen. Das Produkt ist für die menschliche Gesundheit und die Umwelt potenziell nicht gefährlich. Diese können sich aber, falls sie in der Umwelt gelangen, negativ auf diese auswirken. Lesen Sie daher vor dem ersten Gebrauch des Produkts die Inbetriebnahme-, Bedienungs- und Entsorgungsanweisungen sorgfältig durch. Es wird empfohlen, dass Sie das Produkt nur für den vorgesehenen Zweck verwenden. Bei unsachgemäßer Verwendung bzw. Fehlgebrauch besteht die Gefahr eines elektrischen Schlags.



Das Symbol der durchgestrichenen Mülltonne auf dem Etikett des Produkts weist auf die Konformität dieses Produkts zu den Vorschriften für Elektro- und Elektronik-Altgeräte hin. Das Ablagern in der Umwelt oder die illegale Entsorgung des Produkts ist strafbar.



**Safety Warning**

Installation, commissioning and periodical maintenance of the product must be carried out by qualified operators in compliance with national regulations and/or local standards. A qualified installer must take all required measures, including use of Individual Protection Devices, for his and others' safety.

An improper installation may damage people, animals or objects towards which Giacomini S.p.A. may not be held liable.



**Package Disposal**

Carton boxes: paper recycling.  
Plastic bags and bubble wrap: plastic recycling.



**Product Disposal**

Do not dispose of product as municipal waste at the end of its life cycle.

Dispose of product at a special recycling platform managed by local authorities or at retailers providing this type of service.

**Additional information**

For more information, go to [www.giacomini.com](http://www.giacomini.com) or contact our technical assistance service: ☎ +39 0322 923372 📠 +39 0322 923255 ✉ [consulenza.prodotti@giacomini.com](mailto:consulenza.prodotti@giacomini.com)

This document provides only general indications. Giacomini S.p.A. may change at any time, without notice and for technical or commercial reasons, the items included herewith.

The information included in this technical sheet do not exempt the user from strictly complying with the rules and good practice standards in force.

Giacomini S.p.A. Via per Alzo, 39 - 28017 San Maurizio d'Opaglio (NO) Italy